



Installation manual
2009 - 2011
Dodge Ram 1500 4WD (TRX Model)
6" Suspension Kit
Part # 36101

sj03272012rev.02

Part # 36101
2009 - 2011 Dodge Ram 1500 4WD (TRX Model)
6" Suspension kit

Parts contained in Box 1 of 3

<u>Part #</u>	<u>Description</u>	<u>Qty.</u>
34100-12	Skid plate	1
34100-13	DS rear LCA frame bracket	1
34100-14	PS rear LCA frame bracket	1
34100-15	PS track bar relocation frame bracket	1
34100-16	Rear sway bar brake hose bracket	2
36100-CL01	Rear coil springs	2

Parts contained in Box 2 of 3

<u>Part #</u>	<u>Description</u>	<u>Qty.</u>
34100-03	DS front forward differential bracket	1
34100-04	PS front forward differential bracket	1
34100-05	DS front differential pinion mount	1
34100-06	Front cross member	1
34100-07	Rear cross member	1
34100-08	PS front brake hose bracket	1
34100-09	DS front brake hose bracket	1
34100-10	Sway bar endlink extension	2
34100-11	Front drive shaft spacer	1
34100NB1	Hardware bag	1
34100NB2	Hardware bag	1
34100NB3	Hardware bag	1
34100NB4	Hardware bag	1
34100-17	PS rear track bar relocation support bracket	1
34100NB5	Hardware bag	1
34100-18	Upper strut spacer	2
36100-01	DS rear bump stop extension	1
36100-02	PS rear bump stop extension	1
36100-04	Pre-load spacer	2
34100NB6	Hardware bag	1
36101INST	Instruction manual	2
MIRRORHANGER	Rear view mirror hanger	1
WARNINGDECAL	Warning decal	1

Parts contained in Box 3 of 3

<u>Part #</u>	<u>Description</u>	<u>Qty.</u>
34100-01	DS knuckle (RED)	1
34100-02	PS knuckle (YELLOW)	1

Congratulations on your selection to purchase a Tuff Country EZ-Ride Suspension System. We at Tuff Country are proud to offer a high quality product at the industries most competitive pricing. Thank you for your confidence in us, and our product.

If you desire to return your vehicle to stock, it is the customers responsibility to save all stock hardware.

Important customer information:

Tuff Country EZ-Ride Suspension highly recommends that a qualified and/or certified mechanic performs this installation.

This vehicles reaction and handling characteristics may differ from standard cars and/or trucks. Modifications to improve and/or enhance off road performance may raise the intended center of gravity. Extreme caution must be utilized when encountering driving conditions which may cause vehicle imbalance or loss of control. DRIVE SAFELY! Avoid abrupt maneuvers, such as sudden sharp turns which could cause a roll over, resulting in serious injury or death.

It is the customers responsibility to make sure that a re-torque is performed on all hardware associated with this suspension system after the first 100 miles of installation. It is also the customers responsibility to do a complete re-torque after every 3000 miles or after every off road use.

After the original installation, Tuff Country EZ-Ride Suspension also recommends having the alignment checked every 6 months to ensure proper tracking, proper wear on tires and front end components. Tuff Country EZ-Ride Suspension takes no responsibility for abuse, improper installation or improper suspension maintenance.

It is the responsibility of the customer or the mechanic to wear safety glasses at all times when performing this installation.

It is the customers/installers responsibility to read and understand all steps before installation begins. OEM manual should be used as a reference guide.

Make sure to use loctite on all new and stock hardware associated with this installation.

The Tuff Country EZ-Ride Suspension product safety label that is included in your kit box must be installed inside the cab in plain view of all occupants.

Before installation begins, it is the customers/installers responsibility to make sure that all parts are on hand. If any parts are missing, please feel free to call one of our customer service representatives @ (801) 280-2777.

Limited lifetime warranty

Notice to all Tuff Country EZ-Ride Suspension customers: It is your responsibility to keep your original sales receipt! If failure should occur on any Tuff Country EZ-Ride Suspension component, your original sales receipt must accompany the warranted unit to receive warranty. Warranty will be void if the customer can not provide the original sales receipt. Do not install a body lift in conjunction with a suspension system. If a body lift is used in conjunction with any Tuff Country EZ-Ride Suspension product, your Tuff Country EZ-Ride Suspension WARRANTY WILL BE VOID. Tuff Country Inc. ("Tuff Country") suspension products are warranted to be free from defects in material and workmanship for life if purchased, installed and maintained on a non-commercial vehicle; otherwise, for a period of twelve (12) months, from the date of purchase and installation on a commercial vehicle, or twelve thousand (12,000) miles (which ever occurs first). Tuff Country does not warrant or make any representations concerning Tuff Country Products when not installed and used strictly in accordance with the manufacturer's instructions for such installation and operation and accordance with good installation and maintenance practices of the automotive industry. This warranty does not apply to the cosmetic finish of Tuff Country products nor to Tuff Country products which have been altered, improperly installed, maintained, used or repaired, or damaged by accident, negligence, misuse or racing. ("Racing is used in its broadest sense, and, for example, without regards to formalities in relation to prizes, competition, etc.) This warranty is void if the product is removed from the original vehicle and re-installed on that or any other vehicle. This warranty is exclusive and is in lieu of any implied warranty of merchantability, fitness for a particular purpose or other warranty of quality, whether express or implied, except the warranty of title. All implied warranties are limited to the duration of this warranty. The remedies set forth in this warranty are exclusive. This warranty excludes all labor charges or other incidental of consequential damages. Any part or product returned for warranty claim must be returned through the dealer of the distributor from whom it was purchased. Tuff Country reserves the right to examine all parts returned to it for warranty claim to determine whether or not any such part has failed because of defect in material or workmanship. The obligation of Tuff Country under this warranty shall be limited to repairing, replacing or crediting, at its option, any part or product found to be so defective. Regardless of whether any part is repaired, replaced or credited under this warranty, shipping and/or transportation charges on the return of such product must be prepaid by the customer under this warranty.

Important information that needs to be read before installation begins:

If the vehicle that you are working on is not equipped with the factory TRX package, different front pre-load strut spacers will need to be ordered. Please contact Tuff Country or your local Tuff Country dealer and order (2) of part # 36100-03. If the front pre-load strut spacers that are included in this box kit are installed on a vehicle not equipped with the TRX package, the vehicle will be sitting 1" lower in the front than in the rear.

The stock tires and wheels will not work in conjunction with part # 36101. 18" wheels or larger will need to be installed once the suspension kit has been installed. Tuff Country recommends an 18" diameter x 9" wide (maximum width) wheel with a maximum backspacing of 5" or less or a 20" diameter x 9" (maximum width) wheel with a maximum backspacing of 5 1/2" or less. Tuff Country recommends a 37x12.50 tire package. If larger than a 37x12.50 tire is installed on your vehicle in conjunction with part # 36101; Tuff Country assumes no liability and the warranty will be VOID.

Before installation begins, Tuff Country EZ-Ride Suspension highly recommends that the installer performs a test drive on the vehicle. During the test drive, check to see if there are any uncommon sounds or vibrations. If uncommon sounds or vibrations occur on the test drive, uncommon sounds or vibrations will be enhanced once the suspension system has been installed. Tuff Country EZ-Ride Suspension highly recommends notifying the customer prior to installation to inform the customer of these issues if they exist.

New longer rear shocks are needed after this suspension system has been installed and the rear shocks need to be ordered as a separate part #. If you have not already ordered your rear shocks, please feel free to contact Tuff Country or your local Tuff Country dealer and order your rear shocks. Tuff Country recommends installing a 30" fully extended nitrogen gas shock in the rear.

Tuff Country EZ-Ride Suspension highly recommends using a wall mounted strut compressor when installing the strut pre-load spacers into the stock strut. If you do not have access to a wall mounted strut compressor, please take it to your local Dodge dealer to have the strut pre-load spacers installed into the stock strut.

Tuff Country EZ-Ride Suspension packages (2) sets of instruction sheets with this box kit. (1) is for the installer and (1) is for the customer. The (1) for the customer has some post installation procedure literature and it is the installers responsibility to make sure that the customer receives a copy of the installation manual along with the literature.

Hardware bag 34100NB1 includes:

<u>Description</u>	<u>Quantity</u>
516716TUBE (Vacuum line)	1
HC-01 (Hose coupler)	1
34100NB8 (Hardware bag)	1

Hardware bag 34100NB2 includes:

<u>Description</u>	<u>Quantity</u>
M18NLN (18 mm nylock nut)	4
M18150B (18 mm x 150 mm bolt)	4
S10225 (1.265" x .800" x 3.590" sleeve)	4
1122WA (1 1/2" x 2" washer)	4
34SAE (3/4" SAE washer)	8
TL271 (Thread locker 271)	1

Hardware bag 34100NB3 includes:

<u>Description</u>	<u>Quantity</u>
SHOCKTIE (shock tie)	2
M1250B (12 mm x 50 mm bolt)	4
14NLN (1/4" nyloc nut)	2
1434B (1/4" x 3/4" bolt)	2
38FLN (3/8" flange lock nut)	2
381B (3/8" x 1" bolt)	2
716FFN (7/16" fine flange nut)	6
716SAE (7/16" SAE washer)	12

Hardware bag 34100NB4 includes:

<u>Description</u>	<u>Quantity</u>
38FLN (3/8" flange lock nut)	6
381CSB (3/8" x 1" counter sunk bolt)	6

Hardware bag 34100NB5 includes:

<u>Description</u>	<u>Quantity</u>
S10226 (1.265" x .800" x 2.400" sleeve)	2
S10227 (1.140" x .680" x 1.440" sleeve)	1
S10228 (nut bracket)	2
34100NB9 (Hardware bag)	1

Hardware bag 34100NB6 includes:

<u>Description</u>	<u>Quantity</u>
38NLN (3/8" nyloc nut)	4
38SAE (3/8" SAE washer)	4
381B (3/8" x 1" bolt)	4

Hardware bag 34100NB8 includes:

*This hardware bag is packaged inside hardware bag 34100NB1

<u>Description</u>	<u>Quantity</u>
12UN (1/2" unitorque nut)	2
M12WA (12 mm flat washer)	14
M12UN (12 mm unitorque nut)	2
M12LWA (12 mm lock washer)	5
M1240B (12 mm x 40 mm bolt)	5
M1260B (12 mm x 60 mm bolt)	2
12SAE (1/2" SAE washer)	4
12234B (1/2" x 2 3/4" bolt)	2

Hardware bag 34100NB9 includes:

*This hardware bag is packaged inside hardware bag 34100NB5

<u>Description</u>	<u>Quantity</u>
12114B (1/2" x 1 1/4" bolt)	2
516NLN (5/16" nyloc nut)	2
516SAE (5/16" SAE washer)	4
5161B (5/16" x 1" bolt)	2
58UN (5/8" unitorque nut)	4
58SAE (5/8" SAE washer)	8
58412B (5/8" x 4 1/2" bolts)	2
584B (5/8" x 4" bolt)	2
716NLN (7/16" nyloc nut)	4
716SAE (7/16" SAE washer)	8
716114B (7/16" x 1 1/4" bolt)	2
7161B (7/16" x 1" bolt)	2
916NLN (9/16" nyloc nut)	1
916SAE (9/16" SAE washer)	2
916312B (9/16" x 3 1/2" bolt)	1

Special note: Before installation begins, it is the customers/installers responsibility to make sure that all parts are on hand. If any parts are missing, please feel free to call one of our customer service representatives @ (801) 280-2777.

Recommended tools selection:

- Wall mounted strut compressor
- Cut off wheel
- Sawzall
- Torque wrench
- Standard socket set
- Standard wrench set
- Metric socket set
- Metric wrench set
- Tape measure
- Hydraulic floor jacks

Please follow instructions carefully:

Before installation begins, measure from the center of the hub, to the bottom of the fender well, and record measurements below.

Pre-installation measurements:

Driver side front: _____

Passenger side front: _____

Driver side rear: _____

Passenger side rear: _____

At the end of the installation take the same measurements and compare to the pre-installation measurements.

Post installation measurements:

Driver side front: _____

Passenger side front: _____

Driver side rear: _____

Passenger side rear: _____

Before front installation begins and the vehicle is lifted in the air, perform these steps on the rear end. Failure to do so could cause damage to rear end parts. Disconnect the upper end of the track bar. Loosen but do not remove, the track bar at the driver side side axle mount. On both the driver and passenger side, disconnect the upper ends of the anti-sway bar links where they attach to the frame. Disconnect the brake line mount and wheel speed sensor. These are both located on the frame, right behind the coil springs upper mount. Working on the driver side, remove the bolt securing the wire hanger bracket for the parking brake cables located on the lower control arm. Save the stock hardware.

Front end installation:

1. To begin installation, block the rear tires of the vehicle so that the vehicle is stable and can't roll backwards. Safely lift the front of the vehicle and support the frame with a pair of jack stands. Place a jack stand on both the driver and the passenger side. Next, remove the front wheels and tires from both sides.

2. If equipped, remove the front differential skid plate and discard.

3. Disconnect the front drive shaft from the front differential. Save the stock hardware. Also at this time, tie the front drive shaft up and out of the way.

4. Working on the driver side, remove the stock sway bar endlink from the sway bar. Save the hardware. Leave the sway bar end link attached to the lower control arm. Repeat procedure on the passenger side.

5. Working on the driver side, remove the Wheel Speed Sensor wire from the rubber brake hose, the rear leg of the upper control arm and the engine compartment side of the inner fender well. **Special note: This attaching point is just above the rear leg of the upper control arm. Also, pulling the plastic inner fender outboard slightly. Also at this time, disconnect the Wheel speed sensor at the quick disconnect location. Take special care not to damage the quick disconnect.**

6. Working on the driver side, remove the brake caliper from the stock location. Save the stock hardware. **Carefully tie the brake caliper up out of the way in the fender well.**

7. Working on the driver side, remove the rotor and set aside.

8. Working on the driver side, remove the retaining nut from the center of the bearing hub. Set retaining nut aside.

9. Working on the driver side, loosen but do not remove the upper control arm bolts.

10. Working on the driver side, carefully remove the stock knuckle from the upper control arm, lower control arm and outer tie rod. Save the stock hardware. Set the knuckle along with the wheel speed sensor wire aside for now.

11. Working on the driver side, loosen but do not remove the lower control arm bolts.

12. Working on the driver side, remove the stock lower strut hardware that connects the strut to the lower control arm. Save the hardware.

13. Working on the driver side, remove the (3) nuts holding the stock strut into the upper location. Save the stock nuts and carefully remove the strut from the vehicle.

14. Working on the driver side, remove the stock lower control arm cam bolts and lower control arm from the stock location and set aside for later re-installation. **Special note: Before removal of the lower control arm, scribe a DS on the control arm so that you make sure the control arm is re-installed on the driver side of the vehicle.**

Repeat step # 4 - 14 on the passenger side.

15. Working on the driver side, remove the stock rear lower control arm cross member from the stock location. The hardware and cross member may be discarded.

16. Disconnect all electrical and vacuum lines from the front differential. Support the front differential with a differential jack stand. Remove all mounting points for the front differential and remove the front differential from the vehicle completely.

17. Working on the driver side and measuring from the rear

lower control arm pocket from the leading edge towards the driver side 2 1/2", scribe a line around the pocket. Carefully cut along the line to remove part of the rear lower control arm pocket. **Special note: Tuff Country does not recommend using a torch when performing this step. Tuff Country recommends using a cut off wheel or sawzall. After cutting, clean, dress up and paint exposed metal.**

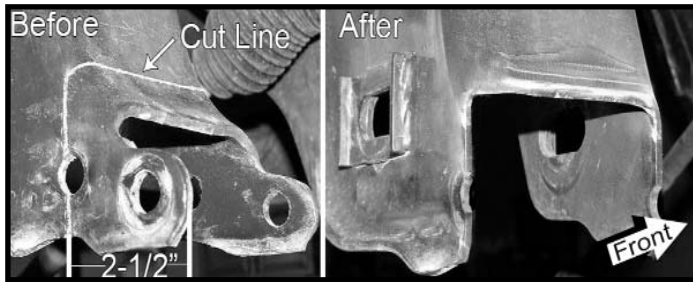

18. Locate the driver side front differential relocation bracket. Also, locate (2) 12 mm x 40 mm bolts, (2) 12 mm lock washers and (2) 12 mm flat washers from hardware bag 34100NB8. Working on the driver side, install the new driver side front differential relocation bracket to the frame using the new 12 mm x 40 mm bolts and hardware. **Do not tighten at this point.**

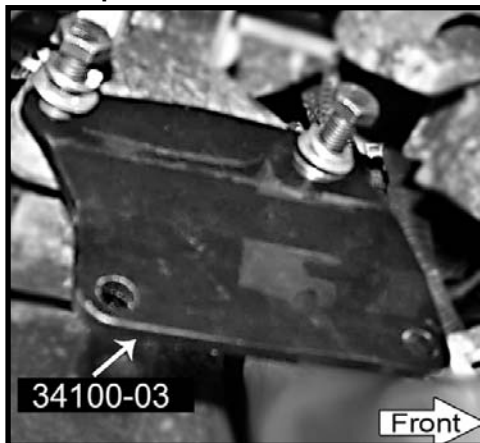

19. Locate the driver side rear differential relocation bracket. Also, locate (3) 12 mm x 40 mm bolts, (3) 12 mm lock washers and (3) 12 mm flat washers from hardware bag 34100NB8. Working on the driver side, install the new driver side rear differential relocation bracket to the frame using the new 12 mm x 40 mm bolts and hardware. **Do not tighten at this point.**

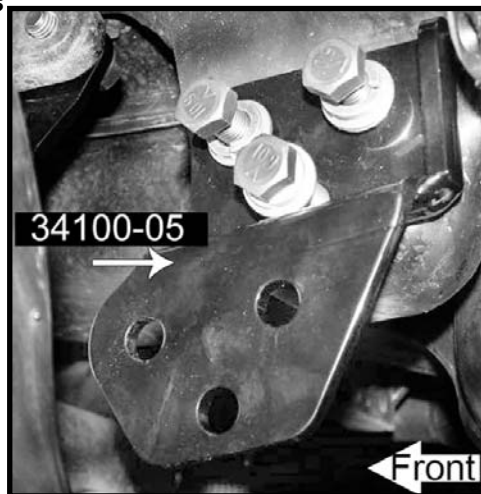

20. Locate the passenger side differential relocation bracket. Locate the passenger side differential stock bolts. Also, locate (4) 12 mm flat washers and (2) 12 mm unitorque nuts from hardware bag 34100NB8. Working on the passenger side, install the new passenger side differential relocation bracket to the frame using the stock bolts and new 12 mm hardware. **Do not tighten at this point.**



21. Working on the driver side of the removed front differential, disconnect the inner CV axle assembly from the differential. **Special note: Using pry bars, positioned between the inner CV and the differential will help free the axles.**

22. Locate (2) 12 mm x 60 mm bolts, (4) 12 mm flat washers and (2) 12 mm unitorque nuts from hardware bag 34100NB8. Using a differential floor jack, bring the front differential under the vehicle and secure the differential to the previously installed driver side front differential relocation bracket using the new 12 mm x 60 mm bolts and hardware. **Do not tighten at this point.**

23. Raise up on the passenger side of the differential housing which will allow the passenger side of the cross member to be attach to the frame. Position the S10225 sleeve in the middle of the factory lower control arm mount then insert the supplied 18 mm x 150 mm bolt and 3/4" flat washer from the front through the cross member and sleeve. Place the 1 1/2" x 2" washer onto the bolt (**this washer is going to seat in the stock rear cam washer location**). Install the supplied flat washer then the 18 mm nylock nut. **Do not tighten at this point.**

24. Raise up on the rear cross member until it seats into the driver side frame. Position the S10225 sleeve in the middle of the factory lower control arm mount then insert the supplied 18 mm x 150 mm bolt and 3/4" flat washer from the front through the cross member and sleeve. Place the 1 1/2" x 2" washer onto the bolt (**this washer is going to seat in the stock rear cam washer location**). Install the supplied flat washer then the 18 mm nylock nut. **Do not tighten at this point.**

25. Locate the (2) 1/2" x 2 3/4" bolts, (4) 1/2" SAE washers and (2) 1/2" unitorque nuts from hardware bag 34100NB8. Working on the passenger side, install the passenger side of the differential to the newly installed passenger side differential relocation bracket and secure using the new 1/2" x 2 3/4" bolts and hardware. **Do not tighten at this point.**

26. Attach the differential to the newly installed driver side rear bracket using the (3) stock differential bolts and the supplied nuts that were earlier removed from the stock cross member.

27. Move back to the (4) bolts securing the driver side / front bracket to the stock location and differential and add some thread locker or loctite and torque to **70 ft lbs**. Move back to the (4) bolts securing the passenger side bracket to the stock location and differential and add some thread locker or loctite and torque to **70 ft lbs**. Move back the the (6) bolts securing the driver side / rear bracket to the stock location and differential and add some thread locker or loctite and torque to **70 ft lbs**.

28. Locate the new vacuum line adapter and vacuum line from hardware bag 34100NB1. Install the vacuum line adapter and new vacuum line. Reconnect the electrical lines, retaining clips may need to be removed to create enough room to reconnect.

29. Locate the new front cross member. Working on the driver side, install the new front cross member into the stock location. **Special note: Make sure the tab with the skid plate holes are towards the rear of the vehicle.** Install the new S10225 in the middle of the stock lower control arm mount then insert the new 18 mm x 150 mm bolt and 3/4" flat washer from the front, then through the cross member and sleeve. Place the 1 1/2" x 2" washer onto the bolt (**this washer is going to seat in the stock rear cam washer location**). Install the supplied flat washer then the 18 mm nylock nut. **Do not tighten at this point.** Repeat procedure on the passenger side.

30. Locate the new front drive shaft spacer. Also, locate (4) new 12 mm x 50 mm bolts from hardware bag 34100NB3. Install the new spacer between the drive shaft and the differential flange and secure using the new 12 mm x 50 mm bolt. Make sure to use thread locker or loctite and torque to **85 ft lbs**.



31. Working on the driver side, install the stock lower control arm into the newly installed front and rear cross member and secure using the stock cam bolts. Install the cam bolts from the front with the cam lobes in the upright centered location. **Do not tighten at this point.**

Tuff Country EZ-Ride Suspension highly recommends using a wall mounted strut compressor when installing the strut pre-load spacers into the stock strut. If you do not have access to a wall mounted strut compressor, please take it to your local Dodge dealer to have the strut pre-load spacers installed into the stock strut.

32. Locate the driver side stock strut assembly. Working on the driver side strut, scribe a line down the entire strut from the top of the strut to the bottom. **Special note: If this step is not performed properly re-installing the strut back into the vehicle will be difficult.**

33. Using a wall mounted strut compressor, carefully compress the driver side stock strut until the upper stock strut bearing plate can be removed. Remove the stock nut and hardware from the top of the stock strut assembly and save the stock hardware for later re-installation.

34. Working on the driver side stock strut, remove the stock upper strut bearing plate from the stock strut assembly. Remove the stock rubber isolator from the stock upper strut bracket and set the stock upper bearing plate and isolator aside for further instructions.

35. Locate (1) new pre-load strut spacer. **If the vehicle that you are working on is not equipped with the factory TRX package, different front pre-load strut spacers will need to be ordered. Please contact Tuff Country or your local Tuff Country dealer and order (2) of part # 36100-03. If the front pre-load strut spacers that are included in this box kit are installed on a vehicle not equipped with the TRX package, the vehicle will be sitting 1" lower in the front than in the rear.** Also, locate the driver side stock strut, the stock bearing plate, the stock isolator and the stock hardware. Carefully compress the stock strut enough so that the new strut spacer and the stock isolator can be installed. Install the new pre-load strut spacer and stock isolator into the stock strut and secure the stock upper bearing plate to stock strut assembly using the stock upper strut hardware. Make sure to use thread locker or loctite and torque to **20 ft lbs**.

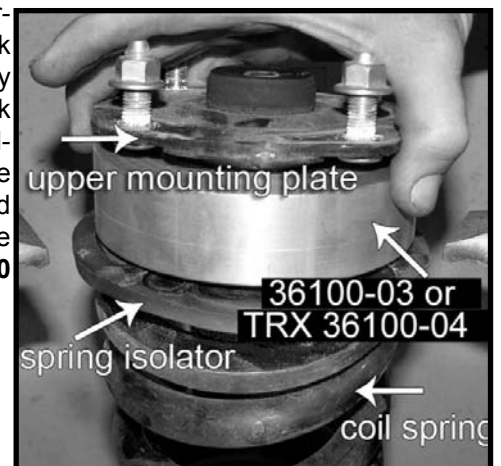

36. Locate the new upper strut spacers. Install the new strut spacer onto the stock struts and secure using the stock hardware. Make sure to use thread locker or loctite and torque to **45 ft lbs.**

37. Locate (6) 7/16" SAE washers and (6) 7/16" flange nuts from hardware bag 34100NB3. Also, locate the lower strut hardware. Working on the driver side, install the modified strut into the upper strut location using the new 7/16" hardware. **Do not tighten at this point.** Now install the bottom of the stock strut into the stock location on the lower control arm. **Do not tighten at this point.** Move back to the upper 7/16" hardware and add some thread locker or loctite and torque to **45 ft lbs.** Repeat procedure on the passenger side.

38. Working on the driver side, insert the inner CV axle shaft into the differential then push firmly to engage CV axle shaft retaining ring. Repeat procedure on the passenger side.

39. Locate where the upper end of the rubber brake hose passes through the frame and connects to a metal brake line. Using a cut off wheel, carefully cut a notch in the frame to allow removal of the brake line or hose. **Special note: Take special care not to damage the brake line or hose.** Remove the brake line bracket bolt then free the line / hose connector from frame. There are a couple bends in the metal lines that are just above the line / hose connector. Carefully straighten out the bends as much as needed to allow the stock brake line bracket to sit flush with the new bracket. **Special note: Take special care not to kink or damage the line.**

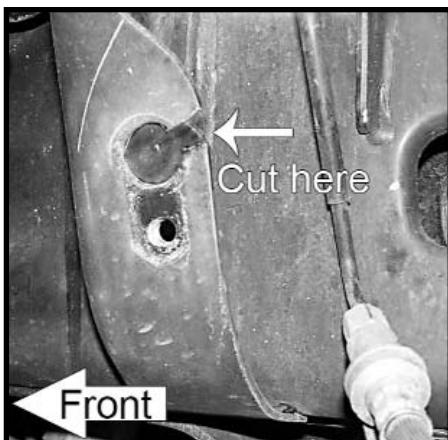

40. Locate the new driver and passenger side brake line relocation brackets. Locate (2) 1/4" x 3/4" bolt and (2) 1/4" nyloc nuts from hardware bag 34100NB3. Working on the driver side, install the new brake line relocation bracket to the stock brake line bracket using the new 1/4" x 3/4" bolt and hardware. **Do not tighten at this point.** Repeat procedure on the passenger side.

41. Locate (2) 3/8" x 1" bolts and (2) 3/8" flange nuts from hardware bag 34100NB3. Also, locate the stock brake line bracket hardware. Working on the driver side, install the newly installed brake line bracket to the frame using the new 3/8" x 1" bolt into the upper location and the stock

hardware into the lower location. Make sure to use thread locker or loctite and torque the 3/8" bolt to **30 ft lbs.** and the stock bolt to **95 in. lbs.** Move back to the 1/4" hardware and add some thread locker or loctite and torque to **95 in. lbs.** Repeat procedure on the passenger side.

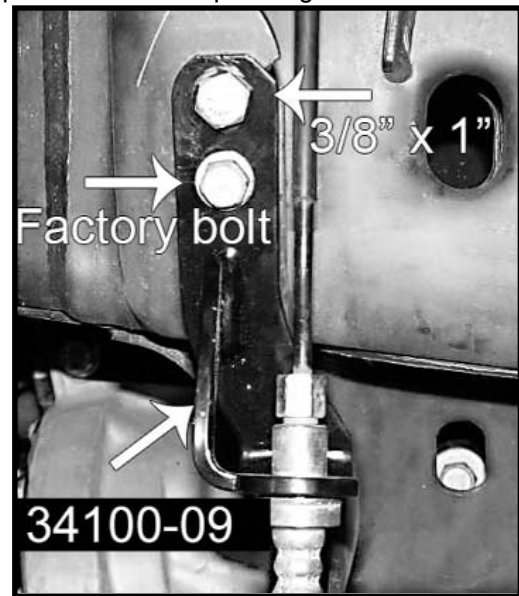

42. Locate the new driver and passenger side knuckles. Also, locate the stock driver and passenger side knuckles. Working on the stock driver side knuckle, remove the bolt that secures the Wheel Speed Sensor wire mounting bracket and now attach the Wheel Speed Sensor wire mounting bracket to the new driver side knuckle in the same orientation that it was removed from the stock knuckle. Repeat procedure on the passenger side stock and new knuckle.

43. Working on the driver side stock knuckle, carefully remove the hub assembly and dust shield. **Special note: Do not disconnect the Wheel Speed Sensor wire for the hub assembly.** Install the stock hub assembly and dust shield to the new driver side knuckle. **Special note: The hub must be positioned with the Wheel Speed Sensor wire routed forward and inside the machined into the knuckle face.** Apply thread locker or loctite to the stock hardware then secure the hub assembly and dust shield to the new knuckle and torque to **95 ft lbs.** Repeat procedure on the passenger side stock and new knuckle.

44. Locate the stock upper and lower ball joint nuts. Also, locate the CV axle shaft nuts and outer tie rod nuts. Working on the driver side, install the new knuckle to the lower control arm and hand tighten the lower control arm nut. Slide the CV axle shaft through the hub bearing and then install the new knuckle to the upper control arm and hand tighten the upper control arm nut. Now install the outer tie rod to the new knuckle using the stock hardware. Add some thread locker or loctite to the CV axle shaft and install the nut and torque to **100 ft lbs.** Add some thread locker or loctite to the upper control arm, lower control arm and outer tie rod nuts and torque the lower control arm nut and outer tie rod nut to **85 ft lbs.** Torque to upper control arm nut to **50 ft lbs.** Repeat procedure on the passenger

side.

45. Working on the driver side, route the Wheel Speed Sensor wire to the mounting bracket on the knuckle as shown in the picture. The rubber grommet on the Wheel Speed Sensor wire must be shifted. Apply some windex on the Wheel Speed Sensor wire and rubber grommet so that the Wheel Speed Sensor wire will slide easily through the rubber grommet. When satisfied with the routing, insert the Wheel Speed Sensor and rubber grommet into the mounting bracket. Repeat procedure on the passenger side.

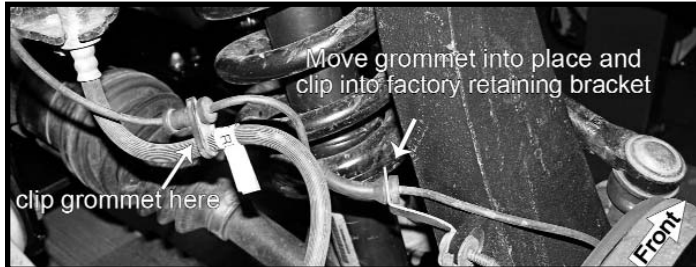

46. Working on the driver side, install the brake rotor and caliper using the stock hardware. Make sure to use thread locker or loctite and torque to **130 ft lbs**. Repeat procedure on the passenger side.

47. Working on the driver side, we are now going to route/attach the Wheel Speed Sensor wire at the following points in this order. At the rubber brake hose, at the rear leg of the upper control arm and then reconnect the Wheel Speed Sensor wire at the quick disconnect point. Special note: We will not be reattaching the connector to the inner fender well. Repeat procedure on the passenger side.

48. Working on the driver side apply some anti-seize to the factory anti-sway bar link threads. Install (3) 7/16" SAE washers per side then install the anti-sway bar link bushings and hardware. Attach anti-sway bar links to anti-sway bar body. Tighten until the bushings start to mushroom. Repeat procedure on the passenger side.

49. Locate the new skid plate. Also, locate the (6) new 3/8" x 1" counter sunk bolts and (6) 3/8" flange lock nuts from hardware bag 34100NB4. Install the new skid plate to the front and rear cross members and secure using the new 3/8" x 1" bolts and hardware. Make sure to use thread locker or loctite and torque to **30 ft lbs**.



50. Working on the driver side add some thread locker or loctite to the hardware attaching the front and rear cross member to the frame mounts. Now torque this hardware to **75 ft. lbs**. Repeat procedure on the passenger side.

51. Install the tires and wheel and carefully lower the vehicle to the ground.

52. Move back to the lower control arm bolts and add some thread locker or loctite and torque both the driver and passenger side to **110 ft lbs**.

53. Move back to the upper control arm bolts and add some thread locker or loctite and torque both the driver and passenger side to **130 ft lbs**.

54. Move back to the lower strut bolt and add some thread locker or loctite and torque both the driver and passenger side to **155 ft lbs**.

55. Block the rear tires of the vehicle so that the vehicle is stable and can't roll backwards. Safely lift the front of the vehicle and support the frame with a pair of jack stands. Place a jack stand on both the driver and the passenger side. Now cycle the steering lock-to-lock and check then double check to make sure that all components have proper clearances. Pay close attention to brake hoses, wiring and tire and wheel clearances. Lower vehicle to the ground.

56. To begin installation, carefully block the front tires and wheels so that the vehicle can not roll forward. Safely lift the rear of the vehicle and support the vehicle with a pair of jack stands. Place a jack stand on both the driver and the passenger side. Next, remove the rear wheels and tires from both sides.

57. Working on the driver the side, remove the stock shock from the stock location. Save the stock hardware. **New longer rear shocks are needed after this suspension system has been installed and the rear shocks need to be ordered as a separate part #. If you have not already ordered your rear shocks, please feel free to contact Tuff Country or your local Tuff Country dealer and order your rear shocks. Tuff Country recommends installing a 30" fully extended nitrogen gas shock in the rear.** Repeat procedure on the passenger side.

58. Carefully lower down on both hydraulic floor jacks at the same allowing just enough room for the rear coil springs to be removed. Remove both the driver and passenger side rear coils and discard.

59. Working on the driver side, loosen but do not remove the stock upper and lower control arms at the axle mount location. Repeat procedure on the passenger side.

60. Working on the driver side, remove the stock upper and lower control arms from the frame mount location. Save the stock hardware and let the control arms hang. Repeat pro-

cedure on the passenger side.

61. Locate the driver and passenger side rear control arm relocation brackets. Also, locate (2) 5/8" x 4" bolts, (2) 5/8" x 4 1/2" bolts, (8) 5/8" SAE washers, (4) 5/8" unitorque nuts and (2) 1/2" x 1 1/4" bolts from hardware bag 34100NB9. Also, locate (2) S10226 sleeves and (2) S10228 nut brackets from hardware bag 34100NB5. Working on the driver side, install the new driver side rear control arm relocation bracket to the stock upper location using the new S10226 sleeve and 5/8" x 4 1/2" bolt and hardware. **Special note: Make sure to install the new bolt from the outside of the vehicle towards the inside of the vehicle and also do not tighten at this point.** Now secure the new bracket to the stock lower control arm location using the new 5/8" x 4" bolt and hardware. **Special note: Make sure to install the new bolt from the outside of the vehicle towards the inside of the vehicle and also do not tighten at this point.** Secure the front part of the bracket to the frame using the new 1/2" x 1 1/4" bolt and nut bracket. **Do not tighten at this point.** Now secure the upper and lower control arms to the newly installed bracket using the stock hardware. **Special note: Make sure to install the new bolt from the outside of the vehicle towards the inside of the vehicle and also do not tighten at this point.** Move back to the new 5/8" hardware and add some thread locker or loctite and torque to **150 ft lbs.** Now move back to the 1/2" hardware and add some thread locker or loctite and torque to **55 ft lbs.** Repeat procedure on the passenger side.

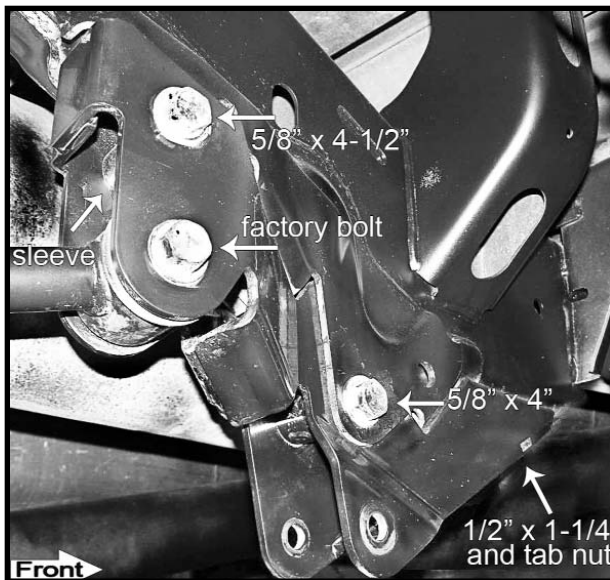

62. Locate the new rear passenger side track bar relocation bracket and the new rear passenger side track bar relocation support bracket. Also, locate (1) 9/16" x 3 1/2" bolt (2) 9/16" SAE washers and (1) 9/16" nyloc nut from hardware bag 34100NB9. Also, locate (1) S10227 sleeve from hardware bag 34100NB5. Install the new rear track bar relocation bracket into the stock location and secure using the new 9/16" hardware and sleeve. Also, make sure to install the support bracket on the rear portion of the stock track bar bracket. Make sure to use thread locker or loctite and torque the new 9/16" bolt to **105 ft lbs.** **Special note: Make**

sure that the rear support bracket is square with the stock bracket. See photo for proper placement. Locate (2) 7/16" x 1 1/4" bolts, (4) 7/16" SAE washers and (2) 7/16" nyloc nuts from hardware bag 34100NB9. Using the newly installed bracket bar bracket and support bracket holes as guides, carefully drill (2) 7/16" holes onto the stock track bar bracket. (1) on the front part of the bracket and one on the rear part of the bracket. Secure the new brackets with the new 7/16" x 1 1/4" bolts and hardware. Make sure to use thread locker or loctite and torque to **50 ft lbs.**

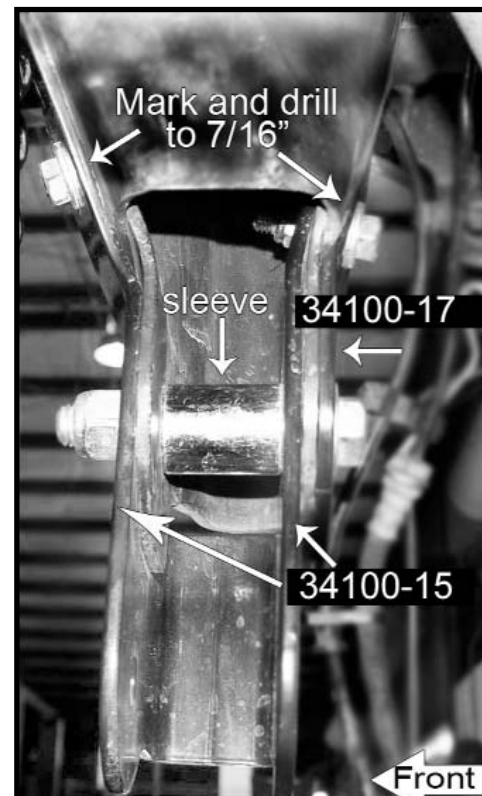
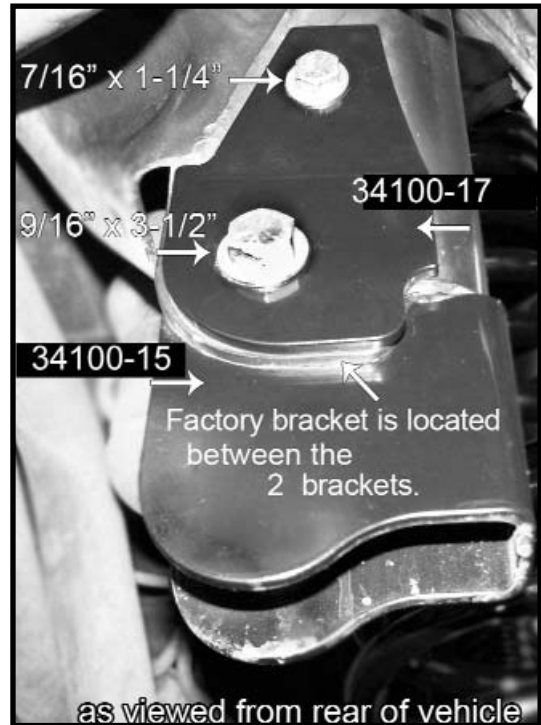

63. Working on the driver side, remove the Wheel Speed Sensor wires from the shock lower mount and the lower coil spring seat. Re-install the front clip into the rear clips hole at the base of the coil spring seat and discard the rear clip. Repeat procedure on the passenger side.



64. Locate the new driver and passenger side bump stop brackets. Also, locate (4) 3/8" x 1" bolts and (4) 3/8" SAE washers and (4) 3/8" nyloc nuts from hardware bag 34100NB6. Working on the driver side, secure the new driver side bump stop bracket on top of the stock bump stop pad and secure using the new 3/8" x 1" bolt and hardware. **Special note: Only use a washer on the nut side of the bolt. Also, make sure to use thread locker or loctite and torque to 30 ft lbs.** Working on the passenger side, install the new passenger side bump stop bracket on top of the stock bump stop pad. Make sure that the bracket is centered on the stock bracket. Using the bracket as a guide, carefully drill (2) 3/8" holes into the stock bracket. Secure the new passenger side bracket to the stock location using the new 3/8" x 1" bolt and hardware. **Special note: Only use a washer on the nut side of the bolt. Also, make sure to use thread locker or loctite and torque to 30 ft lbs.** Passenger side shown.

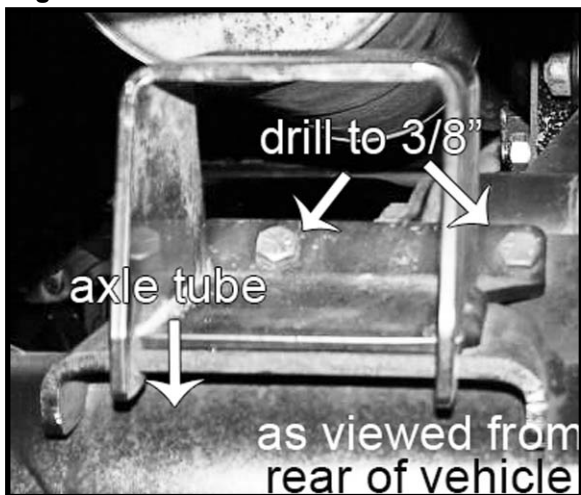

65. Locate the new rear coil springs. Working on the driver side, install the new coil spring into the stock location. Repeat procedure on the passenger side.

66. Locate the new rear shocks. **Special note: New longer rear shocks are needed after this suspension system has been installed and the rear shocks need to be ordered as a separate part #.** If you have not already ordered your rear shocks, please feel free to contact Tuff Country or your local Tuff Country dealer and order your

rear shocks. Tuff Country recommends installing a 30" fully extended nitrogen gas shock in the rear. Working on the driver side, install the new shock into the stock upper and lower location using the stock hardware. Make sure to use thread locker or loctite and torque to **100 ft lbs.** Repeat procedure on the passenger side.

67. Working on the driver side, detach the Wheel Speed Sensor from the stock sway bar links frame bracket. Repeat procedure on the passenger side.

68. Locate (2) rear sway bar/brake hose brackets. Locate (2) 7/16" x 1" bolts, (4) 7/16" SAE washers, (2) 7/16" nyloc nut, (2) 5/16" x 1" bolt, (4) 5/16" SAE washers and (2) 5/16" nyloc nut from hardware bag 34100NB9. Working on the driver side, install the new rear sway bar/brake hose bracket over the stock bracket and secure using the stock hardware on the top hole and the new 7/16" x 1" bolt and hardware in the next hole down. Do not tighten at this point. Using the new 5/16" x 1" bolt and hardware, secure the stock brake line bracket to the newly installed rear sway bar/brake hose bracket. Make sure to use thread locker or loctite and torque to **200 in lbs.** Move back the the upper stock hardware and add some thread locker or loctite and torque to **23 ft lbs.** Now move back to the 7/16" hardware and add some thread locker or loctite and torque to **50 ft lbs.** Now install the stock sway bar end link the the newly installed bracket using the stock hardware. Do not tighten at this point. Repeat procedure on the passenger side.

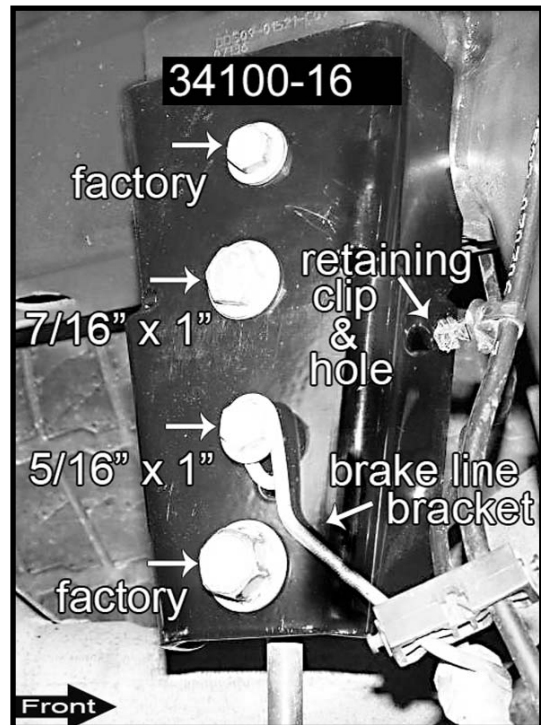

69. Working on the driver side, install the Wheel Speed Sensor wire clip to the front face plate of the newly installed bracket. There are (3) more Wheel Speed Sensor wire clips, lubricate all locations and move the clips so that there is plenty of slack in the lines. Repeat procedure on the passenger side.



70. Install the tires and wheels and carefully lower the vehicle to the ground.

71. Working on the driver side, move back to the stock hardware attaching the upper and lower control arms to the newly installed bracket and add some thread locker or loctite and torque to **210 ft lbs**. Now add some thread locker or loctite to the stock upper and lower control arms where they are attached to the axle mounts and torque to **210 ft lbs**. Repeat procedure on the passenger side.

72. Working on the passenger side, install the stock track bar into the newly installed track bar relocation bracket and secure using the stock hardware. Make sure to use thread locker or loctite and torque to **130 ft lbs**.

73. Working on the driver side, add some thread locker or loctite on the lower track bar hardware and torque to **130 ft lbs**.

74. Working on the driver side, add some thread locker or loctite to the hardware attaching the sway bar end links to the newly installed bracket and torque to **80 ft lbs**. Repeat procedure on the passenger side.

75. Working on the driver side, re-install the parking brake bracket to the driver side lower control arm. **Special note: we just want to make sure that the passenger side cable is in the bracket and the driver side cable is loose.** Add some thread locker or loctite and torque to **35 ft lbs**.

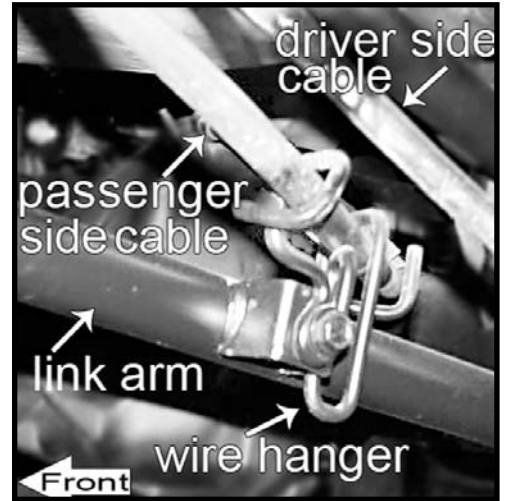

76. Working on the driver side and referring to the picture, trim the liner horizontally on the angled face about the area of contact. Leave the two fasteners intact and trim the liner at an angle on each end to meet the bottom of the liner. Now paint any exposed surfaces. Repeat procedure on the passenger side. **Special note: This step only needs to be performed if contact occurs with the new tires and plastic liner.**

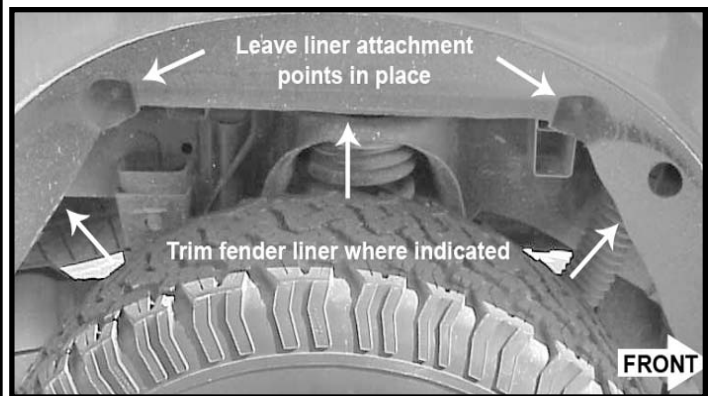

Tuff Country EZ-Ride Suspension recommends that a complete re-torque is done on all bolts associated with this suspension system. It is the customers responsibility to make sure that a re-torque is performed on all hardware associated with this suspension system after the first 100 miles of installation. It is also the customers responsibility to do a complete re-torque after every 3000 miles or after every off road use. Neglect of following these steps could cause brackets to come loose and cause serious damage to the suspension system and to the vehicle.

Tuff Country EZ-Ride Suspension packages (2) sets of instruction sheets with this box kit. (1) is for the installer and (1) is for the customer. The (1) for the customer has some post installation procedure literature and it is the installers responsibility to make sure that the customer receives a copy of the installation manual along with the literature.

If you have any questions or concerns, please feel free to contact Tuff Country or your local Tuff Country dealer.

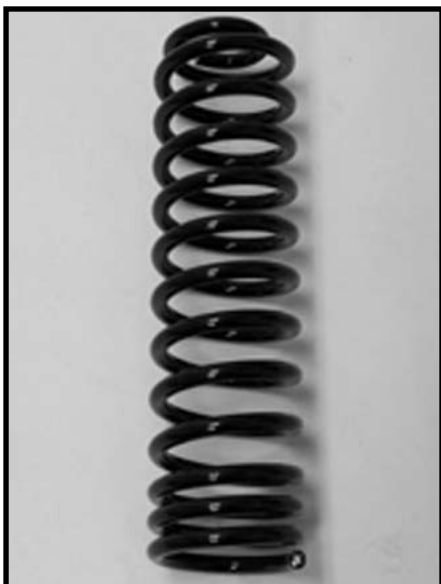

Part # 36100-CL01 / Qty. 2
Rear coil spring

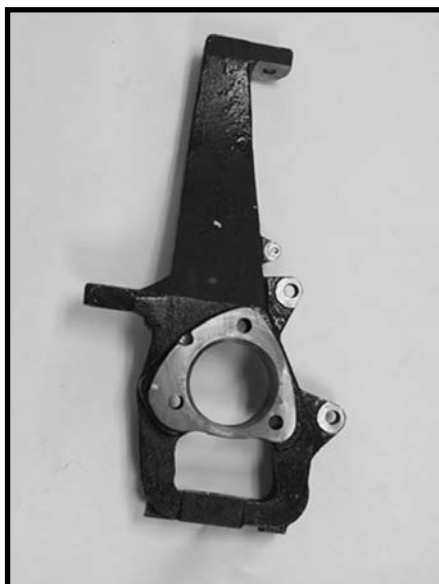

Part # 34100-01 / Qty. 1
Driver side knuckle



Part # 34100-02 / Qty. 1
Passenger side knuckle



Part # 34100-03 / Qty. 1
DS front differential forward mount



Part # 34100-04 / Qty. 1
PS front differential forward mount



Part # 34100-05 / Qty. 1
DS front differential pinion mount



Part # 34100-06 / Qty. 1
Front cross member

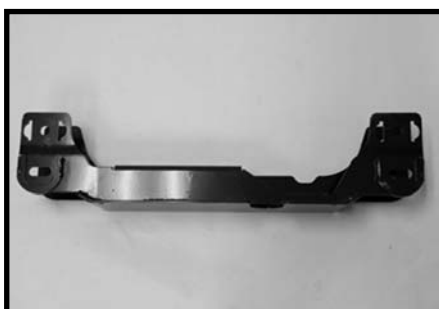

Part # 34100-07 / Qty. 1
Rear cross member



Part # 34100-08 / Qty. 1
PS front brake hose relocation bracket



Part # 36100-04 / Qty. 2
Pre-load spacer



**Part # 34100-09 / Qty. 1
DS front bracket hose
relocation bracket**



**Part # 34100-10 / Qty. 2
Sway bar end link
extension**



**Part # 34100-11 / Qty. 1
Front drive shaft spacer**



**Part # 34100-12 / Qty. 1
Skid plate**



**Part # 34100-13 / Qty. 1
DS rear lower control arm
frame bracket**



**Part # 34100-14 / Qty. 1
Ps rear lower control arm
frame bracket**



**Part # 34100-15 / Qty. 1
PS track bar relocation
frame bracket**



**Part # 34100-16 / Qty. 2
Rear sway bar/brake hose
relocation frame bracket**



**Part # 34100-17 / Qty. 1
PS rear track bar
relocation frame bracket**



**Part # 34100-18 / Qty. 2
Upper strut spacers**



**Part # 36100-01/ Qty. 1
DS rear bump stop
extension**



**Part # 36100-02 / Qty. 1
PS rear bump stop
extension**