



TUFF COUNTRY

EZ-RIDE SUSPENSION

OLD PART NO. T4I3B / NEW PART NO. 54803
 TOYOTA FOUR RUNNER
 4" SUSPENSION SYSTEM
 PARTS LIST:

Qty.	Description	Part No.
2	Rear Lower Link Relocation Bracket	T4IR-01
2	Rear Upper Link Relocation Bracket	T4IR-02
2	Rear Bump Stop Spacer Brackets	T4IR-03
1	Rear Track Bar Drop Bracket	T4IR-04
2	Rear Limiting Straps	T4IR-05
1	Rear Brake Proportioning Bracket	T4IR-06
4	Rear Reinforcement Washers	T4IR-07
2	Rear Lower Link Spacer Sleeves	T4IR-08
2	Rear sway Bar End Links	T4IR-09
1	Rear Extended Brake Line (Steel)	T4IR-10
1	Rear Hardware Box	T4I3B-NB
1	Rear Poly Bag	T4IR-PL
1	Rear Instruction Sheet	54803-INST

Congratulations on your selection to purchase a Tuff Country Suspension System. We at Tuff Country are proud to offer a high quality product at the industries most competitive pricing. Thank you for your confidence in us, and our product.

Check off parts to be sure that all parts are on hand. If any parts are missing, Please call us @ (800) 288-2190

Read and understand all sections of installation manual.

Use locktite on all bolts associated with this installation.

***Important Notes:** Please read before beginning installation. OEM Manual should be used as a reference.

TUFF COUNTRY SUSPENSION highly recommends a qualified and or certified mechanic to perform this installation.

Product safety label must be installed inside the cab in plain view of all occupants.

WARNING

If you desire to return vehicle to stock make sure to save all stock components.

INSTALLATION MANUAL TOYOTA FOUR RUNNER 4" REAR KIT BOX 1990 - 1995 NEW PART # 54803 OLD PART # T4I3B

SJ012201

WARNING: TUFF COUNTRY EZ-RIDE SUSPENSION HIGHLY RECOMMENDS THAT A CERTIFIED MECHANIC PERFORM'S THIS INSTALLATION.

IMPORTANT CUSTOMER INFORMATION

This vehicle's reaction and handling characteristics may differ from standard cars and/or trucks. Modifications to improve and or enhance off road performance may raise the intended center of gravity. Extreme caution must be utilized when encountering driving conditions which may cause vehicle imbalance or loss of control. Drive Safely! Avoid abrupt maneuvers, such as sudden sharp turns, which could cause a roll over, resulting in serious injury or death.

It is the customer's responsibility to make sure a re-torque is performed on all hardware associated with this suspension system after the first 100 miles of installation. It is also the customer's responsibility to do a complete re-torque after every 1000 miles or after every off road use.

After the original installation, Tuff Country also recommends having the alignment checked every 6 months to ensure proper tracking, proper wear on tires and front end components. Tuff Country takes no responsibility for abuse, improper installation, or improper suspension maintenance.

IMPORTANT NOTICE

DO NOT install a body lift in combination with a suspension system. If a body lift is used in conjunction with any Tuff Country Suspension product, your Tuff Country WARRANTY WILL BE VOID.

NOTICE

It is the responsibility of the customer or the mechanic to wear safety glasses at all times when working with air tools.

Please Follow Instruction Carefully

Before installation begins, drive and check to make sure there are not any uncommon sounds and or frame damage. Also at this time measure from the center of the hub to the bottom of fender well and record measurements below.

Pre Installation Measurements:

Driver Side Front _____
Passenger Side Front _____
Driver Side Rear _____
Passenger Side Rear _____

At the end of the installation take the same measurements and compare to the pre installation measurements.

Post Installation Measurement:

Driver Side Front _____
Passenger Side Front _____
Driver Side Rear _____
Passenger Side Rear _____

Please following instructions carefully.

Rear End Installation:

1. To begin installation, block the front tires of the vehicle so that the vehicle is stable and can't roll forwards. Safely lift the front of the vehicle and support the frame with jack stands. Place a jack stand on both the driver and the passenger side. Next, remove the wheels and tires from both sides.

2. Place a pair of hydraulic floor jack under the driver and passenger side of the rear axle. Raise up on both hydraulic floor jacks at the same time until they come in contact with the rear axle.

3. Working on the driver side, remove the stock shock and save hardware for later re-installation. The stock shock may be discarded. Repeat procedure on passenger side.

4. Working on the driver side, remove the stock brake proportioning valve bracket that is connected to the stock rear track bar and save hardware for later re-installation. Tie the stock brake proportioning valve bracket out of the way.

5. Remove the stock brake hose clip from the upper stock location and save for later re-installation. Remove the stock brake hose. **Special Note: Remove the upper connection first then the lower connection.** The stock brake hose may be discarded. Locate the new brake hose and new retaining "E" clip. Install the new brake hose into the stock

location, attach the lower connection first and then the upper connection. Re-install the stock retaining clip. **Special Note: The stock retaining clip may need to be spread slightly to fit the new brake hose. Also the new "E" clip may need to be installed.** After the completion of the installation you will need to bleed the brake system.

See Illustration # 1

6. Working on the driver side, remove the stock sway bar end link from the stock frame location and the stock sway bar. Save the upper hardware for later re-installation. The lower hardware and stock end link may be discarded. Repeat procedure on passenger side.

7. Working on the passenger side, remove the stock rear track bar from the stock location and save hardware for later re-installation. Let stock rear track bar hang.

8. Locate the stock hole on the outside of the stock track bar bracket. Measure up in a straight line exactly 3 3/16", scribe a mark on the outside of the stock bracket. Drill a 7/16" hole into the stock rear track bar bracket.

See Illustration # 2

9. Locate (1) new passenger side rear track bar relocation bracket, (1) 7/16" x 1 1/4" bolt, (2) 7/16" flat washers, (1) 7/16" unitorque nut, (1) 5/8" x 3" bolt, (2) 5/8" flat washers and (1) 5/8" unitorque nut. Install the new passenger side rear track bar relocation bracket into the stock passenger side location and secure using the 7/16" x 1 1/4" bolt and hardware. **Do not tighten at this point.** Using the new 5/8" x 3" bolt and hardware, secure the new passenger side rear track bar relocation bracket to the stock passenger side location. Torque the 7/16" bolt to 35 ft lbs. Torque the 5/8" bolt to 115 ft lbs.

See Illustration # 3

10. Working on the driver side, remove the stock upper and lower link from the stock axle location. Save hardware for later re-installation. Repeat procedure on passenger side.

11. Working on the driver side, remove the parking brake cables that connect to the bottom side of the stock lower link. Save hardware for later re-installation. Repeat procedure on passenger side.

12. Working on the driver side, remove the stock lower link from the stock frame location and save stock lower link for later re-installation. Save stock hardware for later re-installation. Repeat procedure on passenger side.

13. Lower down on both hydraulic floor jacks at the same time until the stock rear coil springs can be removed. Working on the driver side, remove the stock rear coil clip and save stock rear coil clip and stock hardware for later re-installation. (If so equipped). Remove the stock rear coil spring and discard. Repeat procedure on passenger side.

14. Working on the driver side, remove the stock coil bump stop and save for later re-installation. The stock bolt may be discarded. Repeat procedure on passenger side. **Do not tighten at this point.** Repeat procedure on passenger side.

See Illustration # 7

15. Locate (2) new bump stop spacer, (2) 8 mm x 120 mm bolt. Working on the driver side, install the new bump stop spacer between the stock bump stop and the stock bump stop location. Secure using new 8 mm x 120 mm bolt. Torque to **20 ft. lbs.** Repeat procedure on passenger side.

See Illustration # 4

16. Locate (2) new rear upper link relocation brackets, (2) 5/8" x 4" bolt, (4) 5/8" flat washers, (2) 5/8 unitorque nuts, (4) 7/16" x 1" bolt, (8) 7/16" flat washers, (4) 7/16" unitorque nuts, (8) 7/16" ID x 1 1/2" OD washers and (4) reinforcement washers. Working on the driver side, install the new rear upper link relocation bracket into the stock location and secure using the new 5/8" x 4" bolt and hardware into the stock location. **Do not tighten at this point.** Install (2) new 7/16" x 1" bolt, (4) 7/16" ID x 1 1/2" OD washers, (2) reinforcement washers and (2) 7/16" unitorque nuts into the two lower holes in the stock upper link bracket. **Do not tighten at this point.** Repeat procedure on passenger side.

See Illustration # 5

17. Locate (2) new rear lower link frame relocation brackets, (2) rear lower link frame relocation anti crush sleeves, (4) 5/8" x 4 1/2" bolts, (8) 5/8" flat washers, (4) 5/8" unitorque nuts, (4) 7/16" x 1 1/4" bolts, (8) 7/16" flat washers and (4) 7/16" unitorque nuts. Working on the driver side, install the new rear lower link frame relocation bracket to the stock location and secure using new 5/8" x 4 1/2" bolt and hardware. Also make sure to use the new anti crush sleeve. **Do not tighten at this point.** Using the (2) holes on the bottom half of the new rear lower link frame relocation bracket as a guide, carefully drill (2) 7/16" hole into bottom of the stock frame. Secure the newly drilled holes in the bottom of the frame and the new rear lower link frame relocation bracket with (2) new 7/16" bolts and hardware. **Do not tighten at this point.** Repeat procedure on passenger side.

See Illustration # 6

18. Locate (2) new rear coil springs. Working on the driver side, install the rear coil spring into the stock location and secure using the stock coil clip and hardware. (If so equipped). Repeat procedure on passenger side. Raise up on both hydraulic floor jacks at the same time until the newly installed coil springs seat properly into the stock location.

19. Working on the driver side, install the stock lower link to the axle location and secure using stock hardware. **Do not tighten at this point.** Next, install the stock lower link to the newly installed lower link frame relocation bracket and secure using the stock hardware. **Special Note: Raising the axle to ride height and moving it slightly up and down will make for easier installation. Slight prying of the stock lower link bracket also may be needed to make installation easier.**

20. Working on the driver side, install the stock upper link to the newly installed upper link relocation bracket and secure using stock hardware. **Special Note: Raising the axle to ride height and moving it slightly up and down will make for easier installation. Slight prying of the new upper link bracket also may be needed to make installation easier. Do not tighten at this point.** Repeat procedure on passenger side.

See Illustration # 8

21. Locate (2) new rear sway bar end links, (2) poly bushing, (2) anti crush sleeves, (2) 1/2" x 2 1/2" bolts, (4) 1/2" flat washers, (2) 1/2" unitorque nuts and the stock upper sway bar end link bushings and nuts that were removed from step # 6. On both new end links, install the new poly bushing into the bottom eyelets. **Special Note: Make sure to use a lithium or moly base grease prior to inserting bushings into end links. This will increase the life of the bushing as well as prevent squeaking.**

22. Working on the driver side, install the new sway bar end link to the stock sway bar and secure using the new 1/2" x 2 1/2" bolt and hardware. **Do not tighten at this point.** Next, install the new end link into the upper frame location and secure using the stock hardware that was removed from step # 6. **Do not tighten at this point.** Repeat procedure on passenger side.

See Illustration # 9

23. Working on the driver side, drill a 1/2" hole into the upper stock shock mount. Refer to illustration # 10 for proper placement. Repeat procedure on passenger side.

See Illustration # 10

24. Working on the driver side, install the new shock into the stock upper location and secure using the stock hardware. **Special Note: Shocks are not included with this suspension system. Tuff Country recommends using a 26" fully extended gas shock.** Repeat procedure on passenger side.

25. Locate (2) limiting straps, (2) 1/2" x 1" bolt, (2) 1/2" flat washer and (2) 1/2" unitorque nut. Working on the driver side, install the new limiting strap to the upper stock shock mount in the newly drilled hole. Secure using the new 1/2" x 1" bolt and hardware. Torque to **70 ft lbs.** Repeat procedure on passenger side.

See Illustration # 10

26. Working on the driver side, install the lower shock mount and the lower part of the limiting strap to the stock location and secure using the stock hardware. Torque to **70 ft lbs.** Repeat procedure on passenger side.

See Illustration # 10

27. Locate (1) new brake proportioning valve bracket, (2) 8 mm x 30 mm bolt and (2) 8 mm unitorque nuts. Working on the driver side, install the new brake proportioning valve bracket to the stock location on the stock rear track bar and secure using the stock hardware. **Do not tighten at this point.** Next, install the stock brake proportioning valve bracket to the newly installed brake proportioning valve bracket and secure using the new 8 mm x 30 mm bolts and hardware. Torque the stock hardware and the newly installed hardware to **20 ft. lbs.**

See Illustration # 11

28. Check and double check to make sure that all steps were performed properly. Next, move back to all new and stock hardware and torque to proper specifications. Refer to the torque setting on this page.

29. Working on the driver side, install the rear tires and wheels. Repeat procedure on passenger side. Remove both hydraulic floor jacks from under the vehicle. Safely lower the vehicle to the ground.

30. Once the weight of the vehicle is on the ground, jump up and down on the bumper to allow the springs to seat properly. Once the weight is on the ground, install the passenger side of the rear track bar to the newly installed rear track bar bracket and secure using the stock hardware. Torque to **85 ft. lbs.**

See Illustration # 12

31. It is now time to bleed the brake system. This part of the installation will take (2) people to complete this procedure.

32. Fill the master cylinder with the approved brake fluid.

33. Have one person pump on the brake pedal 5 times and hold. Have the other person open up the wheel cylinder bleeder nut to purge air from the system. Close the bleeder nut when the pedal reaches the floor. Continue the bleeding process until only fluid (no air) is discharged. Make sure to bleed each wheel and replenish the master cylinder with the approved brake fluid after each process.

34. Bleed the proportioning valve, using the same procedure as the brakes. Check and double check to make sure that there are not any leaks in the fittings.

Congratulations Installation Complete

Torque Settings:

5/16"	15-18 ft. lbs.	3/8"	28-32 ft.lbs.
7/16"	30-35 ft. lbs.	1/2"	65-85 ft. lbs.
9/16"	75-90 ft. lbs	5/8"	85-110 ft. lbs.
3/4"	105-125 ft. lbs.		

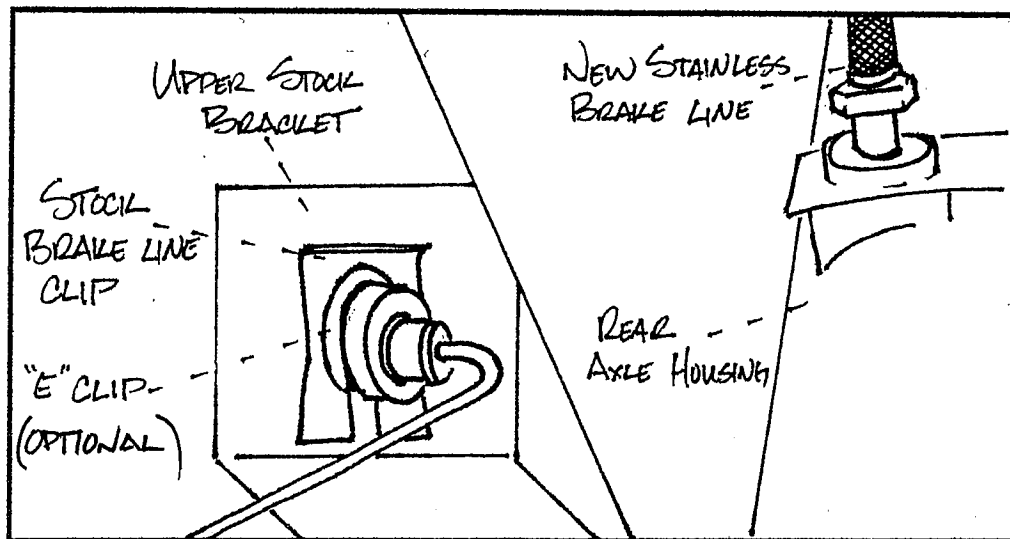

ILLUSTRATION # 1

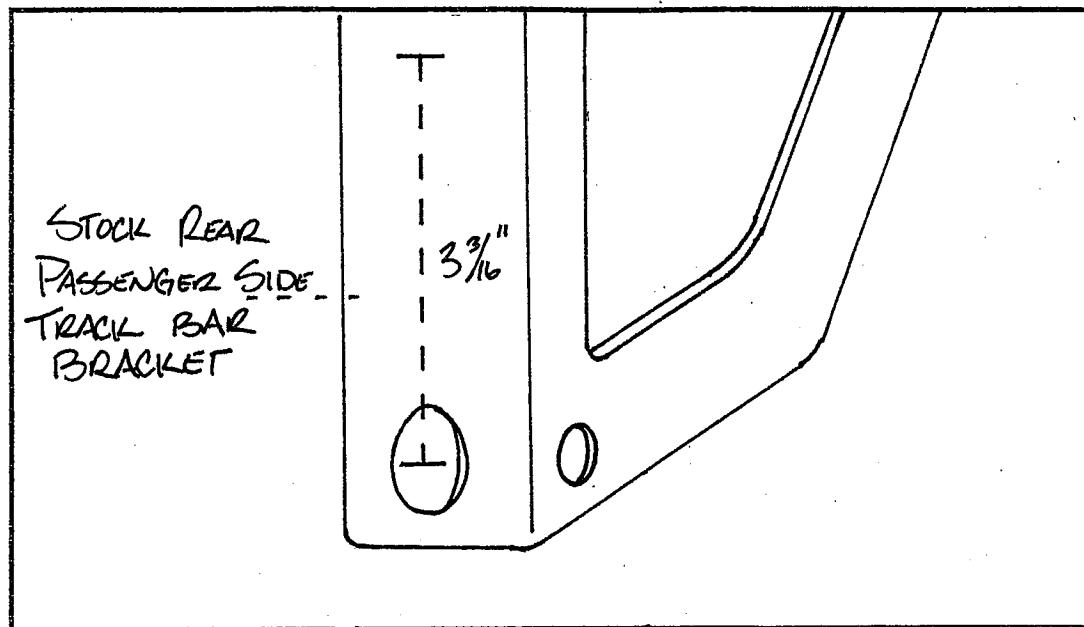

ILLUSTRATION # 2

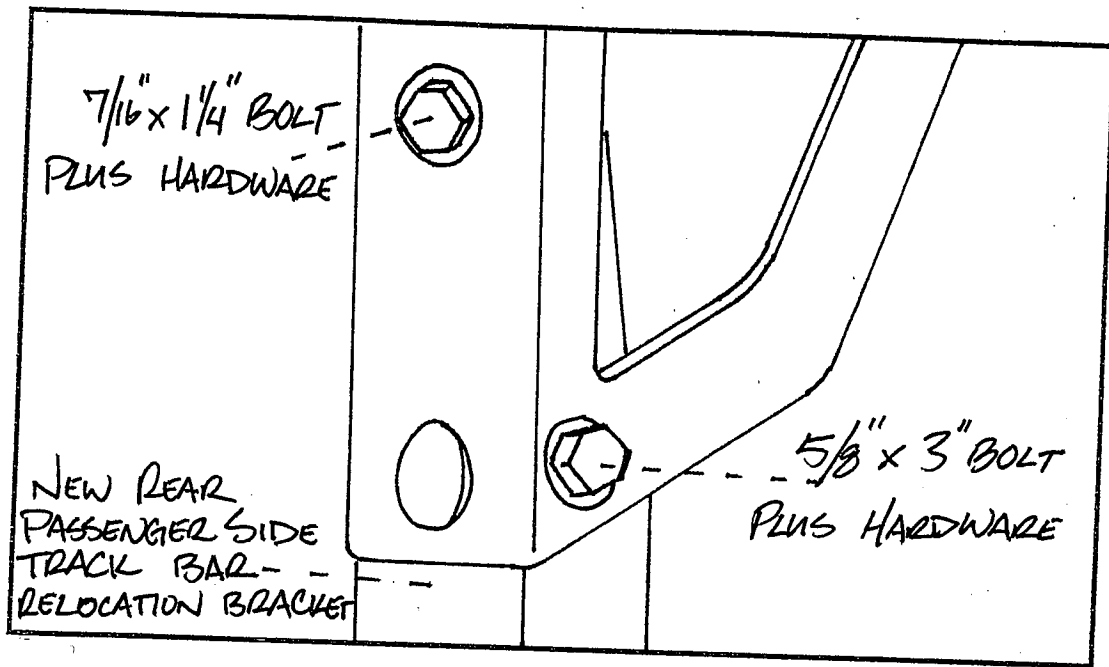

ILLUSTRATION # 3

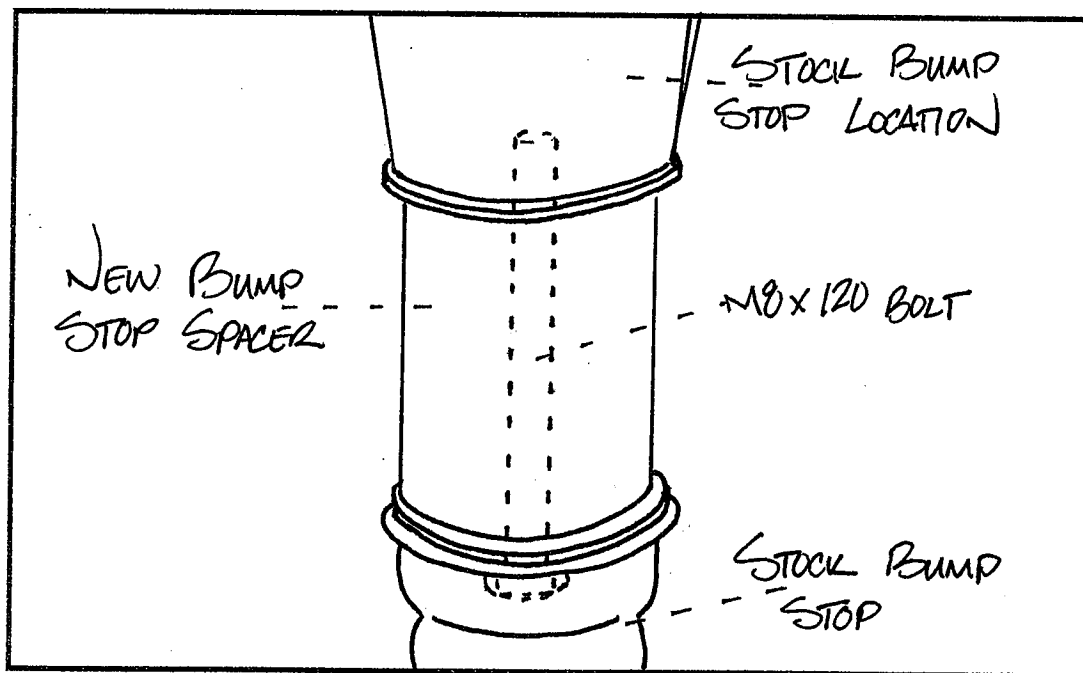

ILLUSTRATION # 4

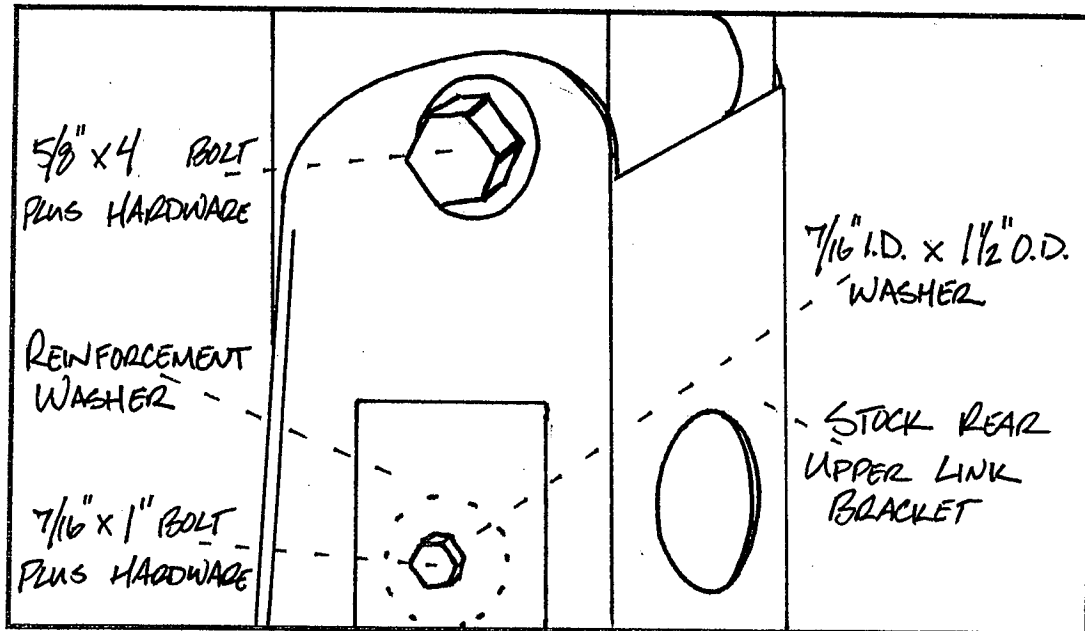

ILLUSTRATION # 5

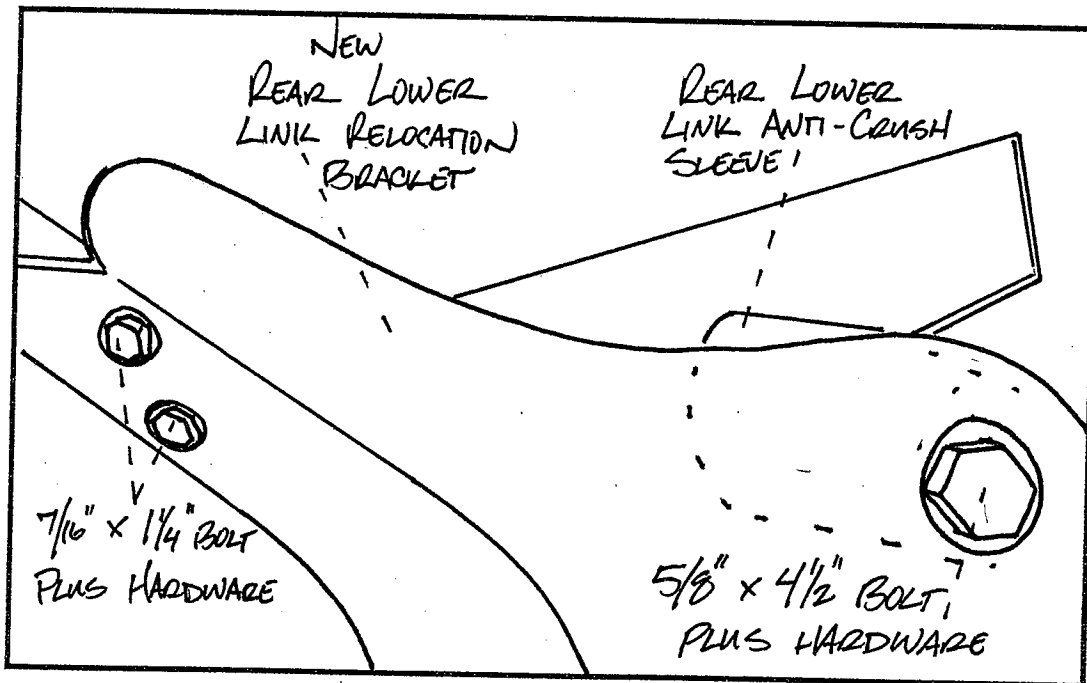

ILLUSTRATION # 6

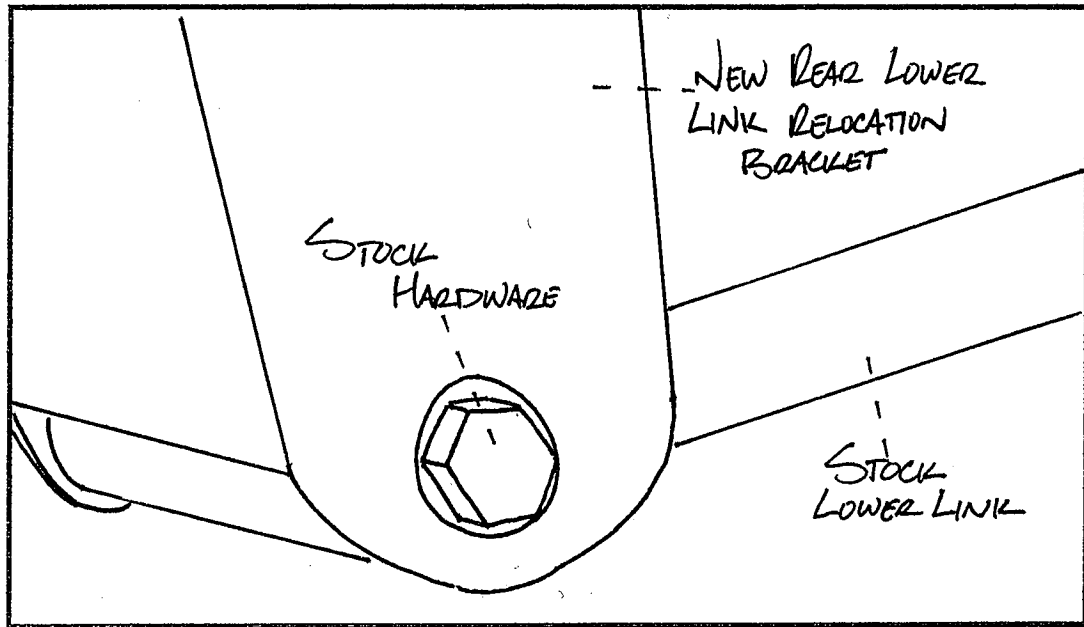

ILLUSTRATION # 7

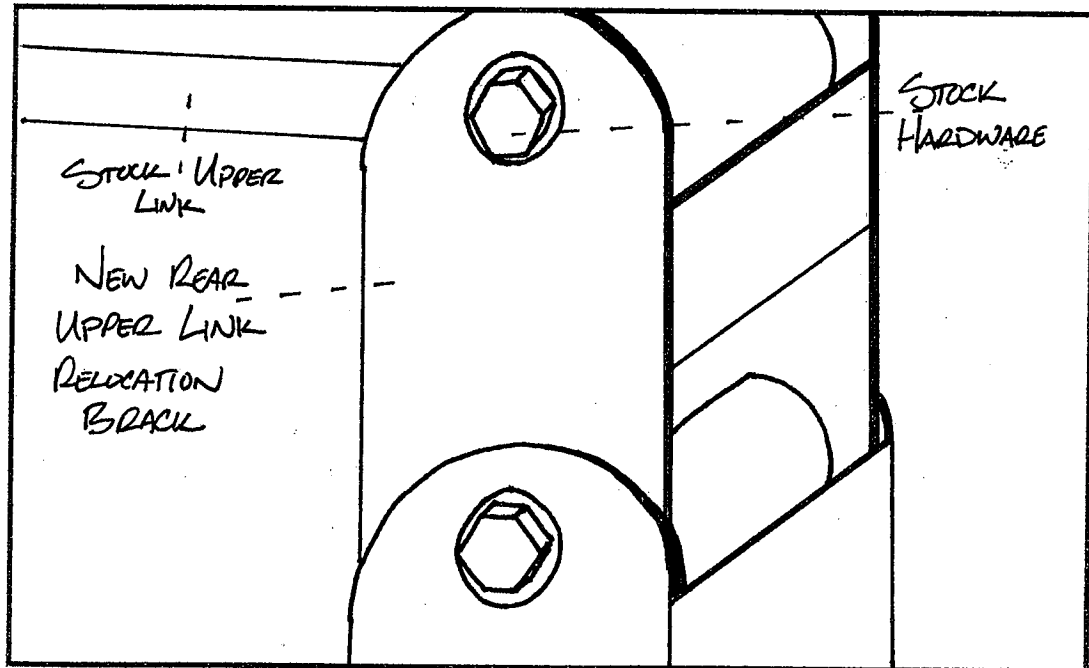

ILLUSTRATION # 8

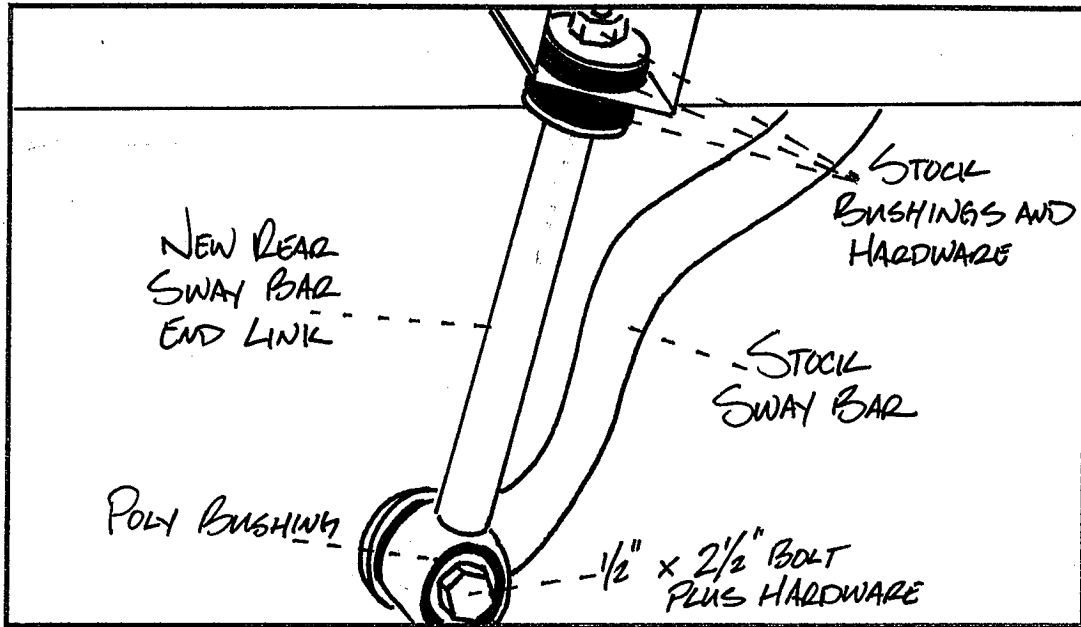

ILLUSTRATION # 9

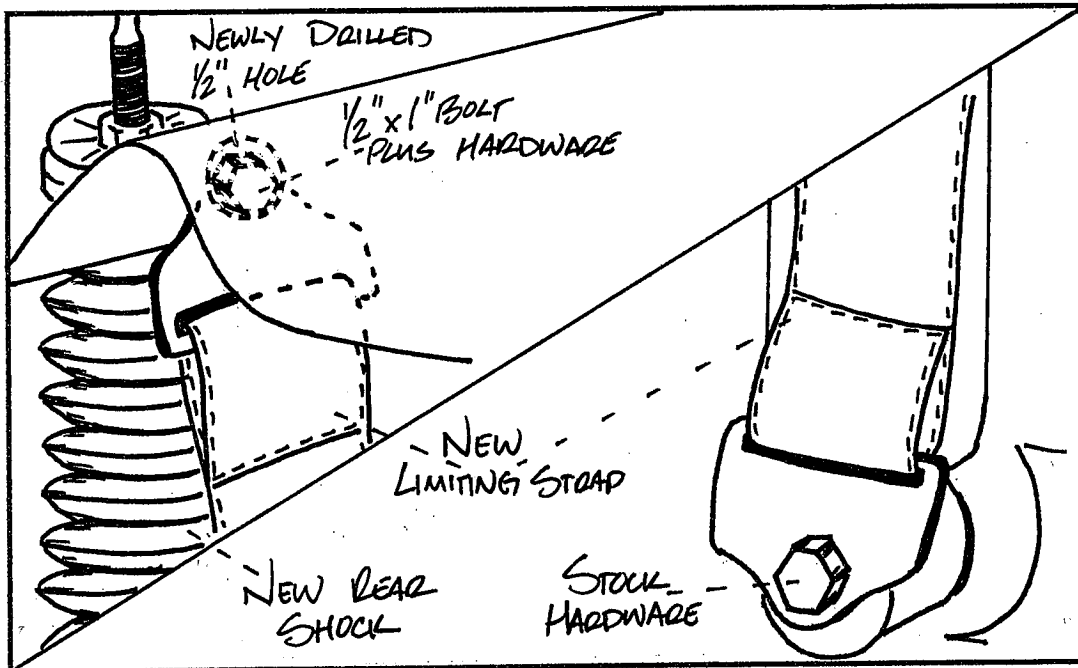

ILLUSTRATION # 10

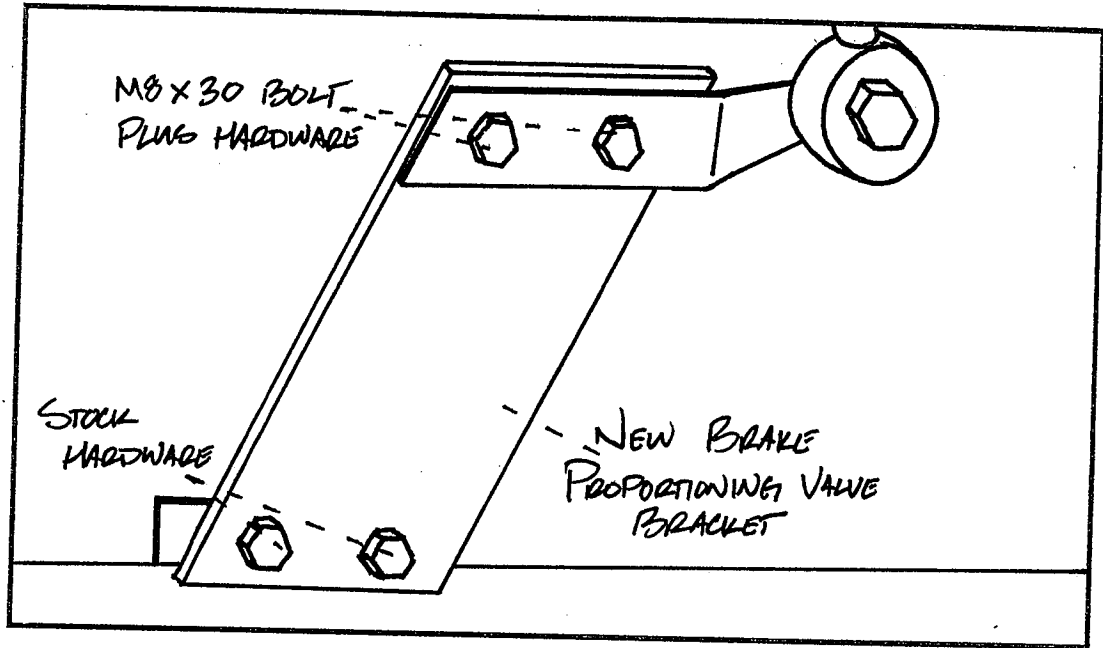

ILLUSTRATION # 11

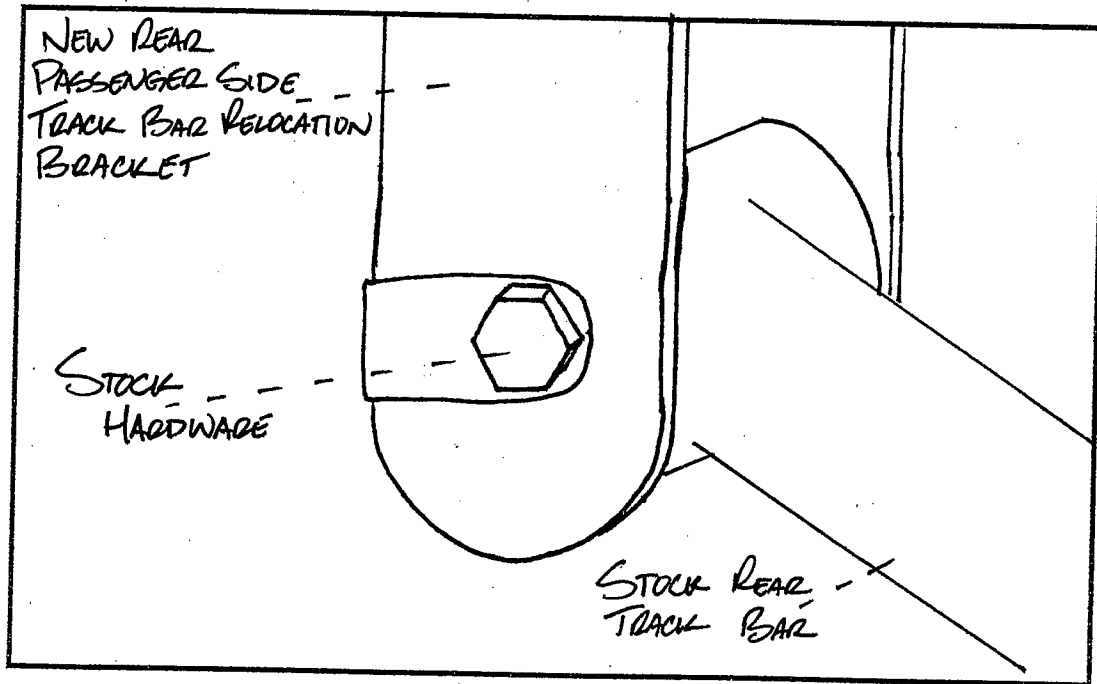

ILLUSTRATION # 12