



EZ - Ride Suspension

PART NUMBER : 20823
1980 — CURR "F" SERIES VEHICLES
ADJUSTABLE CARRIER BEARING DROP

PARTS LIST:

Part #	Description	Qty.
FCB-02	One Piece Adjustable Drop	1
28023NB	Hardware Bag	1
20823INST	Instruction Sheet	1

Congratulations on your selection to purchase a Tuff Country EZ-Ride Suspension System. We at Tuff Country are proud to offer a high quality product at the industries most competitive pricing. Thank you for your confidence in us, and our product.

Before installation begins, it is the customers/ installers responsibility to make sure that all parts are on hand. If any parts are missing, please feel free to call one of our customer service representative @ (800) 288-2190.

Make sure to use loctite on all new and stock hardware associated with this installation.

It is the responsibility of the installers to make sure that the rear view mirror hanger is hung from the rear view mirror. The rear view mirror hanger has instructions on proper post installation procedures.

Torque Settings

5/16"	15—18 ft lbs.
3/8"	28—32 ft lbs.
7/16"	30—35 ft lbs.
1/2"	65—85 ft lbs.
9/16"	85—120 ft lbs.
5/8"	95—130 ft lbs.
3/4"	100—140 ft lbs.

INSTALLATION MANUAL ADJUSTABLE CARRIER BEARING DROP 1980 — CURR "F" SERIES VEHICLES PART # 20823

SJ100802

IMPORTANT CUSTOMER INFORMATION

Tuff Country EZ-Ride Suspension highly recommends that a qualified and or certified mechanic performs this installation.

If you desire to return your vehicle to stock, it is the customers responsibility to save all stock hardware.

This vehicles reaction and handling characteristics may differ from standard cars and/or trucks. Modifications to improve and/or enhance off road performance may raise the intended center of gravity. Extreme caution must be utilized when encountering driving conditions which may cause vehicle imbalance or loss of control. **DRIVE SAFELY!** Avoid abrupt maneuvers, such as sudden sharp turns which could cause a roll over, resulting in serious injury or death.

It is the customers responsibility to make sure that a re-torque is performed on all hardware associated with this suspension system after the first 500 miles of installation. It is also the customers responsibility to do a complete re-torque after every 3000 miles or after every off road use.

After the original installation, Tuff Country EZ-Ride Suspension also recommends having the alignment check every 6 months to ensure proper tracking, proper wear on tires and front end components. Tuff Country EZ-Ride Suspension take no responsibility for abuse, improper installation or improper suspension maintenance.

It is the responsibility of the customer or the mechanic to wear safety glasses at all times when performing this installation.

It is the customers/installers responsibility to read and understand all steps before installation begins. OEM manual should be used as a reference guide.

The Tuff Country EZ-Ride Suspension product safety label that is included in your kit box must be installed inside the cab in plain view of all occupants.

Tuff Country EZ-Ride Suspension offers the new adjustable carrier bearing drop brackets to help eliminate any rear drive line vibration that may occur in a vehicle that has had an after market lifted kit installed. Due to the stock vibration that may occur, Tuff Country EZ-Ride Suspension can not guarantee that all vibrations will be eliminated. If any questions occur during installation, please feel free to contact Tuff Country or your local Tuff Country Dealer.

Vehicles that are going to drop the carrier bearing down 1/4", please follow step # 1 - 5

Vehicles that are going to drop the carrier bearing down more than 1/4", please follow steps 6 - 11

1. Place a hydraulic floor jack under the rear driveline near the stock carrier bearing. Raise up on hydraulic floor jack until the jack makes contact with the rear drive line.

2. Carefully remove the (2) stock bolts that hold the stock carrier bearing to the stock location. The stock hardware may be discarded. Also, remove the stock keeper nuts from the stock location on the upper stock carrier bearing bracket. The keeper nuts may be discarded.

3. Carefully lower the hydraulic floor jack approximately 1". **Special Note: Take special care not to allow rear drive line to slid out of the stock location.**

4. Locate the new adjustable carrier bearing drop bracket, (2) 7/16" x 1 1/4" bolts, (4) flat washers, (2) 7/16" unitorque nuts and (2) 7/16" lock washers. Install the new adjustable carrier bearing drop over the stock carrier bearing bracket. Raise up on the hydraulic floor jack until the carrier bearing seats flush with the new adjustable bracket. Secure the carrier bearing to the stock carrier bearing bracket using the new 7/16" x 1 1/4" bolts and hardware. **Torque to 45 ft lbs.**

See Illustration # 1

5. Carefully remove the hydraulic floor jack from under the rear drive line.

6. Place a hydraulic floor jack under the rear driveline near the stock carrier bearing. Raise up on hydraulic floor jack until the jack make contact with the rear drive line.

7. Carefully remove the (2) stock bolts that hold the stock carrier bearing to the stock location. The stock hardware may be discarded. Also, remove the stock keeper nuts from the stock location on the upper stock carrier bearing bracket.

8. Carefully lower the hydraulic floor jack approximately 1". **Special Note: Take special care not to allow rear drive line to slid out of the stock location.**

9. Locate the new adjustable carrier bearing drop bracket, (2) 3/8" x 1 1/4" bolts, (4) 3/8" flat washers, (2)

3/8" unitorque nuts and (2) lock washers. Install the new adjustable carrier bearing drop over the stock carrier bearing bracket. Raise up on the hydraulic floor jack until the carrier bearing seats flush with the new adjustable bracket. **Special Note: Make sure that the new adjustable carrier bearing bracket is centered over the stock bracket.** Using the new side holes in the new carrier bearing drop bracket as a guide, drill a 3/8" hole in the stock carrier bearing bracket. **See Illustration # 2 for proper placement of the drilled holes.** Secure the new adjustable carrier bearing bracket to the stock bracket using the new 3/8" x 1 1/4" bolt and hardware. **Do Not tighten at this point.**

See Illustration # 2

10. Locate (2) 7/16" x 1 1/4" bolts, (4) flat washers, (2) 7/16" unitorque nuts, (2) 7/16" lock washers. Lower down on the hydraulic floor jack approximately 1/2". Secure the stock carrier bearing to the new adjustable carrier bearing drop using the new 7/16" x 1 1/4" bolt and hardware. **Torque to 42 ft lbs.** Using a magnetic angle indicator, raise up or down on the hydraulic floor jack until the correct angle is found. Once the correct angle is found, move back to the (4) 3/8" bolts and **torque to 38 ft lbs.**

See Illustration # 3

11. Carefully remove the hydraulic floor jack from under the rear drive line.

Congratulations Installation Complete

Special Note: After installation of the new adjustable carrier bearing drop bracket, drive the vehicle to make sure that there are no vibrations. If a vibration occurs, adjustment of the new adjustable carrier bearing may be needed.

If you have any question or concerns about the new carrier bearing drop you may contact your local Tuff Country dealer or you may contact Tuff Country direct.

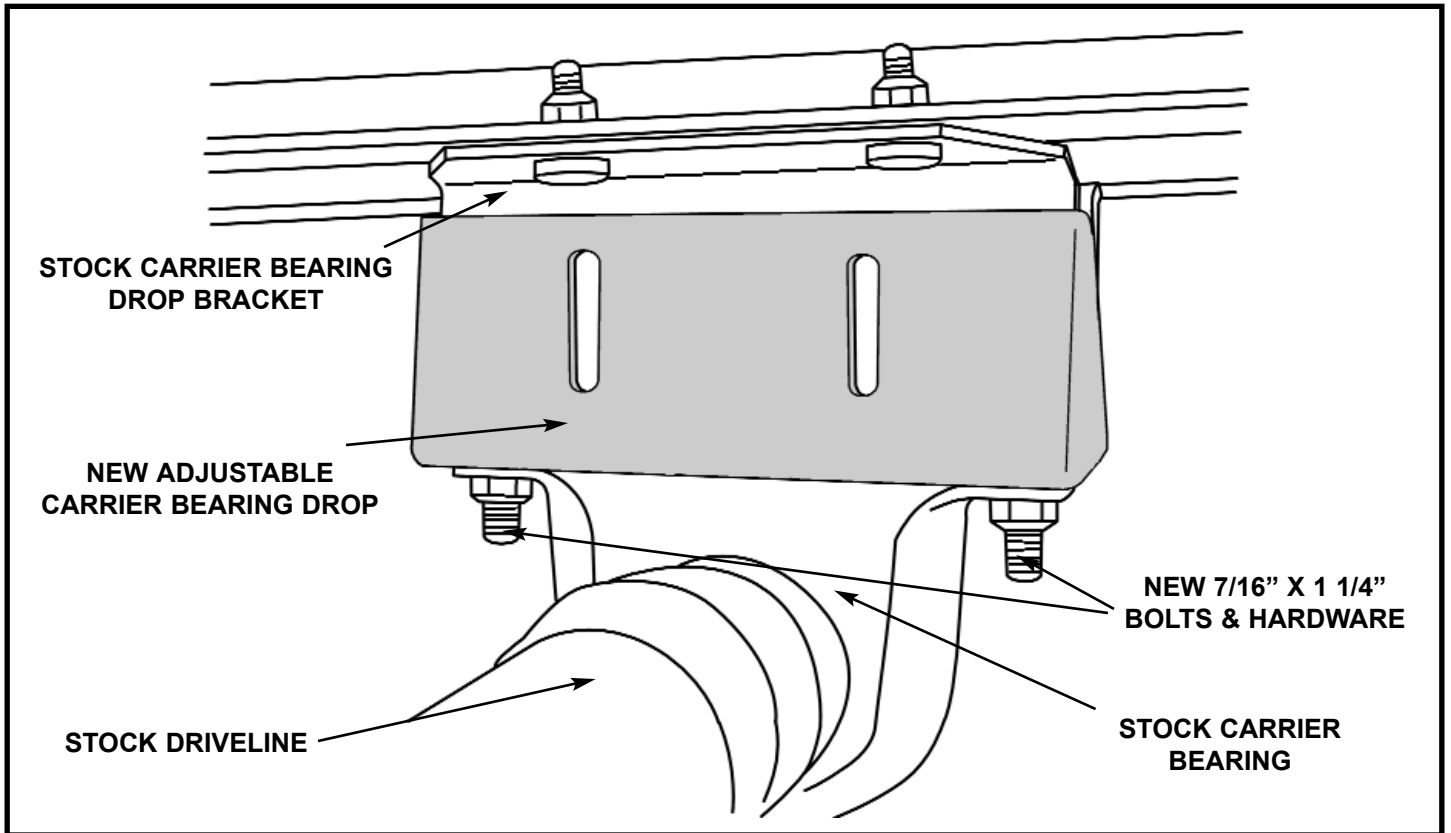

ILLUSTRATION # 1

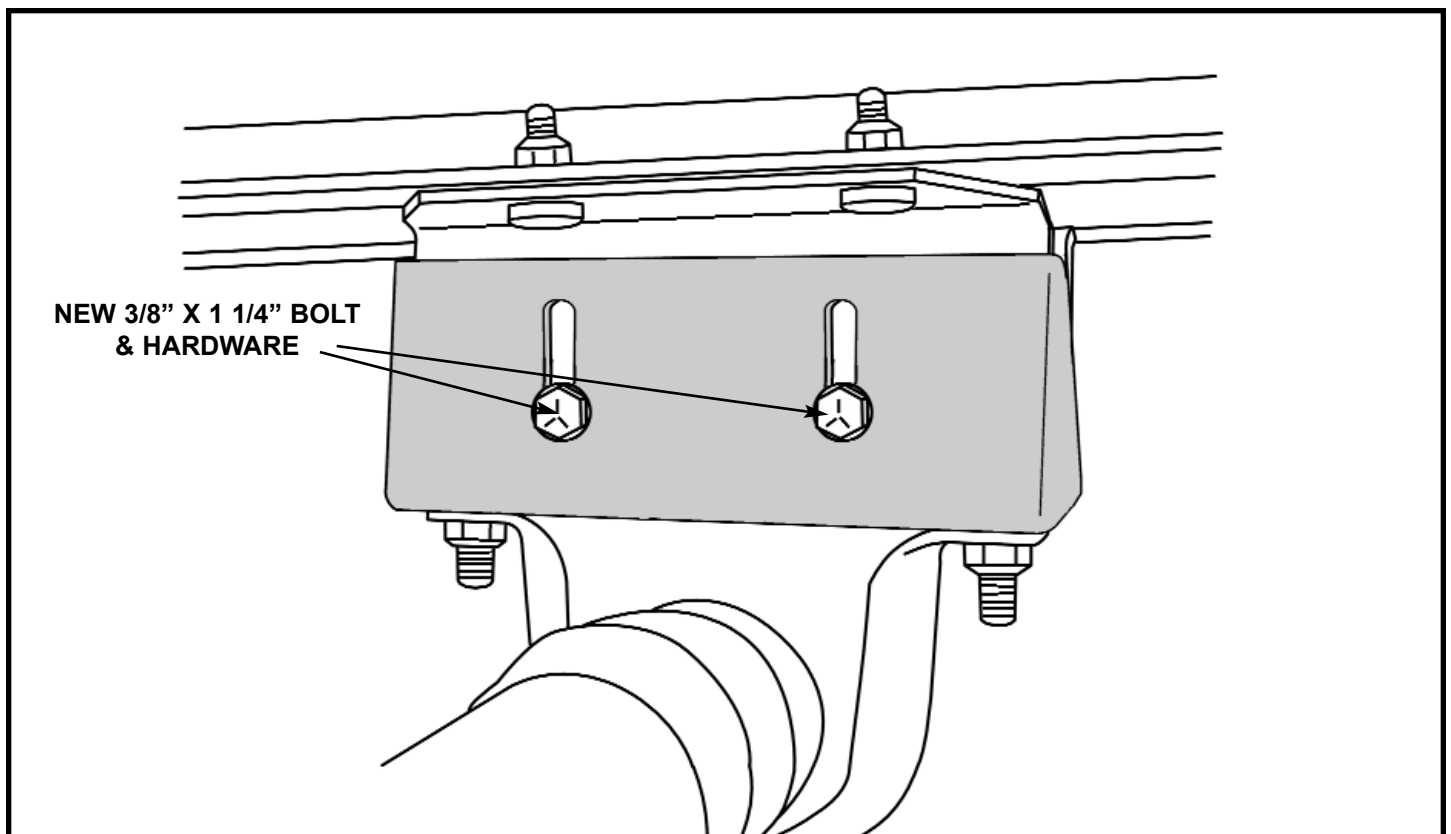

ILLUSTRATION # 2

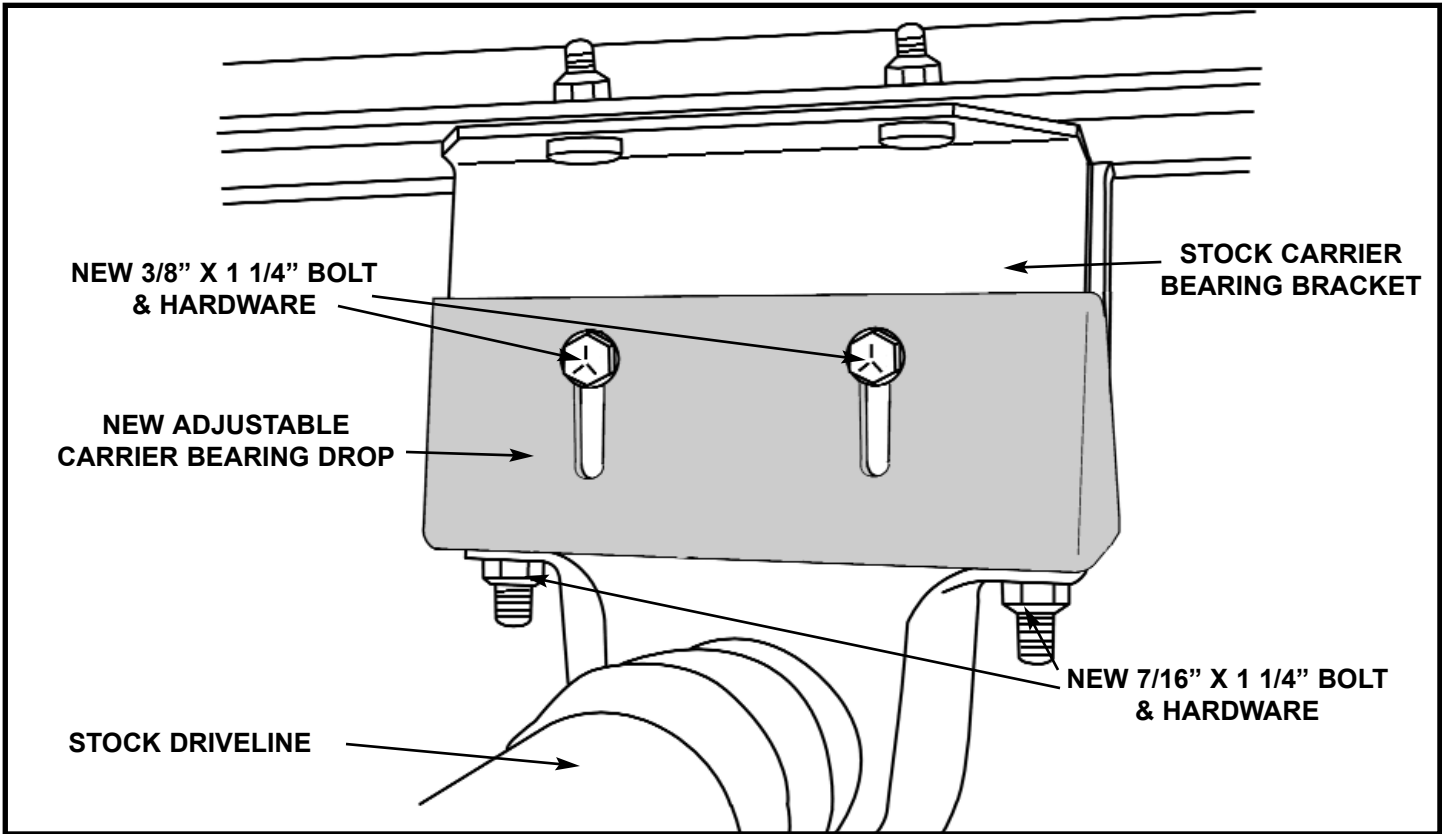

ILLUSTRATION # 3