



## EZ - Ride Suspension

# INSTALLATION MANUAL 1997 FORD F250 4" SUSPENSION SYSTEM PART # 24821

020303rev.01

**PART NUMBER : 24821**  
**1997 FORD F250**  
**4" SUSPENSION SYSTEM**

<b>Part #</b>	<b>Description</b>	<b>Qty.</b>
F4250-05	Rear Twin "I" Beam Axle Pivot Drop Bracket	1
F4250-06	Front Twin "I" Beam Axle Pivot Drop Bracket	1
F405	Front Sway Bar Drop Bracket	2
BL403	4" Rear Lifted Blocks	2
TCI-R22	Rear Add-A-Leafs	2
5U-3814R	5/8" x 3 5/8" x 14 1/2" Round U-Bolts	4
5U-2510S	9/16" x 3" x 10 1/2" Square U-bolts	4
S10008	Front Spring Eye Shackle Sleeve	2
MO2070	Front Spring Eye Shackle Bushings	4
916NW	Hardware Bag	1
58NW	Hardware Bag	1
CB38	Hardware Bag	1
CAM1NB	Hardware Bag	1
F4250NB	Hardware Bag	1
F2507NB	Hardware Bag	1
LUBE	Poly Lube Pack	4
24821INST	Instruction Sheet	1

### IMPORTANT CUSTOMER INFORMATION

Tuff Country EZ-Ride Suspension highly recommends that a qualified and or certified mechanic performs this installation.

If you desire to return your vehicle to stock, it is the customers responsibility to save all stock hardware.

This vehicles reaction and handling characteristics may differ from standard cars and/or trucks. Modifications to improve and/or enhance off road performance may raise the intended center of gravity. Extreme caution must be utilized when encountering driving conditions which may cause vehicle imbalance or loss of control. **DRIVE SAFELY!** Avoid abrupt maneuvers, such as sudden sharp turns which could cause a roll over, resulting in serious injury or death.

It is the customers responsibility to make sure that a re-torque is performed on all hardware associated with this suspension system after the first 100 miles of installation. It is also the customers responsibility to do a complete re-torque after every 3000 miles or after every off road use. Also, after the original installation, Tuff Country EZ-Ride Suspension also recommends having the alignment check every 6 months to ensure proper tracking, proper wear on tires and front end components. Tuff Country EZ-Ride Suspension take no responsibility for abuse, improper installation or improper suspension maintenance.

It is the customers/installers responsibility to read and understand all steps before installation begins. OEM manual should be used as a reference guide.

The Tuff Country EZ-Ride Suspension product safety label that is included in your kit box must be installed inside the cab in plain view of all occupants.

It is the responsibility of the installers to make sure that the rear view mirror hanger is hung from the rear view mirror. The rear view mirror hanger has instructions on proper post installation procedure.

It is the responsibility of the customer or the mechanic to wear safety glasses at all times when performing this installation.

**Special Note:** This box kit includes the rear lifted blocks, rear add-a-leafs, front and rear U-bolts, front and rear twin "I" beam axle pivot drop brackets, front sway bar drop brackets and necessary hardware. Tuff Country EZ-Ride Suspension offers two styles of front springs, a spring used in conjunction with a gas engine and a spring used in conjunction with a diesel engine. If you have not already ordered your front springs, please contact Tuff Country or your local Tuff Country dealer and order (2) 28480 (Gas Engine) or (2) 28481 (Diesel Engine). Also, some vehicles with a 460 engine, may need to install (2) 28481 springs due to the weight of the engine.

A new pitman arm is needed once the suspension systems has been installed. The new pitman arm is sold as a separate part number. If you have not already ordered your new pitman arm, please contact Tuff Country or your local Tuff Country dealer and order (1) 70200

Congratulations on your selection to purchase a Tuff Country EZ-Ride Suspension System. We at Tuff Country are proud to offer a high quality product at the industries most competitive pricing. Thank you for your confidence in us, and our product.

Make sure to use locktite on all new and stock hardware associated with this installation.

## LIMITED LIFETIME WARRANTY

Notice to all Tuff Country EZ-Ride Suspension customers: It is your responsibility to keep your original sales receipt! If failure should occur on any Tuff Country EZ-Ride Suspension component, your original sales receipt must accompany the warranted unit to receive warranty. Warranty will be void if the customer can not provide the original sales receipt. Do not install a body lift in conjunction with a suspension system. If a body lift is used in conjunction with any Tuff Country EZ-Ride Suspension product, your Tuff Country EZ-Ride Suspension **WARRANTY WILL BE VOID.** Tuff Country Inc. ("Tuff Country") suspension products are warranted to be free from defects in material and workmanship for life if purchased, installed and maintained on a non-commercial vehicle; otherwise, for a period of twelve (12) months, from the date of purchase and installation on a commercial vehicle, or twelve thousand (12,000) miles (which ever occurs first). Tuff Country does not warrant or make any representations concerning Tuff Country Products when not installed and used strictly in accordance with the manufacturer's instructions for such installation and operation and accordance with good installation and maintenance practices of the automotive industry. This warranty does not apply to the cosmetic finish of Tuff Country products nor to Tuff Country products which have been altered, improperly installed, maintained, used or repaired, or damaged by accident, negligence, misuse or racing. ("Racing is used in its broadest sense, and, for example, without regards to formalities in relation to prizes, competition, etc.) This warranty is void if the product is removed from the original vehicle and re-installed on that or any other vehicle. This warranty is exclusive and is in lieu of any implied warranty of merchantability, fitness for a particular purpose or other warranty of quality, whether express or implied, except the warranty of title. All implied warranties are limited to the duration of this warranty. The remedies set forth in this warranty are exclusive. This warranty excludes all labor charges or other incidental or consequential damages. Any part or product returned for warranty claim must be returned through the dealer of the distributor from whom it was purchased. Tuff Country reserves the right to examine all parts returned to it for warranty claim to determine whether or not any such part has failed because of defect in material or workmanship. The obligation of Tuff Country under this warranty shall be limited to repairing, replacing or crediting, at its option, any part or product found to be so defective. Regardless of whether any part is repaired, replaced or credited under this warranty, shipping and/or transportation charges on the return of such product must be prepaid by the customer under this warranty.

### Hardware Bag 916NW Includes:

<u>Disription</u>	<u>Quantity</u>
9/16" U-Bolt High Nuts	8
9/16" U-bolt Harden Washers	8

### Hardware Bag 58NW Includes:

<u>Disription</u>	<u>Quantity</u>
5/8" U-Bolt High Nuts	8
5/8" U-bolt Harden Washers	8

### Hardware Bag CB38 Includes:

<u>Disription</u>	<u>Quantity</u>
3/8" x 6" Rear Centering Bolts	2
3/8" Fine Nuts	2

### Hardware Bag F4250NB Includes:

<u>Disription</u>	<u>Quantity</u>
7/16" x 1 1/2" Bolts	4
7/16" Unitorque Nuts	4
7/16" Flat Washers	8

### Hardware Bag F2507NB Includes:

<u>Disription</u>	<u>Quantity</u>
9/16" x 1 1/2" Bolts	10
9/16" Unitorque Nuts	10
9/16" Flat Washers	20

### Hardware Bag CAM1NB Includes:

<u>Disription</u>	<u>Quantity</u>
9/16" x 3 1/2" Cam Bolts	2
Cam Washers	4
9/16" Unitorque Nuts	2

**Special Note:** Before installation begins, it is the customers/installers responsibility to make sure that all parts are on hand. If any parts are missing, please feel free to call one of our customer service representative @ (800) 288-2190.

**Drilling Required:** Due to the inconsistencies and different variations in Ford's mounting location for the stock twin "I" beam axle pivot drop brackets, the new twin "I" beam axle pivot drop brackets will require (3) 9/16" holes drilled into each bracket prior to installation.

**Special Note: Tuff Country EZ-Ride Suspension recommends running a 35" x 12.50" tire for maximum tire clearance. Note: This tire size is not 100% accurate due to variations in wheel width, wheel off set, tire diameters and driving habits.**

**Please Follow Instruction Carefully**

Before installation begins, drive and check to make sure there are no uncommon sounds and or frame damage. Also at this time measure from the center of the hub to the bottom of the fender well and record measurements below.

**Pre Installation Measurements:**

Driver Side Front: \_\_\_\_\_  
Passenger Side Front: \_\_\_\_\_  
Driver Side Rear: \_\_\_\_\_  
Passenger Side Rear: \_\_\_\_\_

At the end of the installation take the same measurements and compare to the pre-installation measurements.

**Post Installation Measurements:**

Driver Side Front: \_\_\_\_\_  
Passenger Side Front: \_\_\_\_\_  
Driver Side Rear: \_\_\_\_\_  
Passenger Side Rear: \_\_\_\_\_

**Please follow instructions carefully:**

**Front End Installation:**

1. To begin installation, block the rear tires of the vehicle so that the vehicle is stable and can't roll backwards. Safely lift the front of the vehicle and support the frame with jack stands. Place a jack stand on both the driver and passenger side. Next, remove the wheels and tires from both sides.

2. Working on the driver side, remove the stock shock from the stock upper and lower mounting point and save the stock hardware for later re-installation. The stock shock may be discarded. **Special Note: New longer front shocks are needed after the completion of the installation. If you have not already ordered your front shocks, please contact Tuff Country or your local Tuff Country dealer and order part # 61261.** Repeat procedure on the passenger side.

3. Working on the driver side, remove the stock castle nut and cotter pin that connects the stock pitman arm to the stock drag link. Save the stock castle nut and cotter pin for later re-installation. Carefully break the taper on the stock drag link and stock pitman. **Special Note: Take special care not to rip or tear the dust boot on the stock drag link.** Next, remove the stock nut and

washer that connect the stock pitman arm to the stock sector shaft. Save the stock nut and washer for later re-installation. Using a pitman arm puller, carefully remove the stock pitman arm from the sector shaft on the stock steering box. A new pitman arm is needed, the stock pitman arm may be discarded. **Special Note: The new pitman arm is sold as a separate part number. If you have not already ordered your new pitman arm, please contact Tuff Country or your local Tuff Country dealer and order (1) 70200.**

**See Illustration # 1**

**Special Note: If the vehicle that you are working on is not equipped with a stock front sway bar, please skip to step # 5**

4. Working on the driver side, disconnect the stock sway bar from the stock frame mount and save the stock hardware for later re-installation. Repeat procedure on the passenger side.

5. Place a pair of hydraulic floor jacks under the front twin "I" beam axle.

6. Working on the driver side, remove the stock U-bolts from the stock location. The stock U-bolts and hardware may be discarded. Place the stock upper and lower U-bolt plates a side for later re-installation.

7. Working on the stock front twin "I" beam axle pivot drop bracket, remove the stock bolt that connects the stock front twin "I" beam axle to the stock front twin "I" beam axle pivot drop bracket and discard the stock hardware.

8. Carefully lower down on the hydraulic floor jacks that are supporting the front twin "I" beam axle approximately 5". **Special Note: Take special care not to kink or over extend any brake lines and or hoses.** This will allow enough room for the new front springs and new front twin "I" beam axle pivot drop bracket to be installed into the stock location.

9. Next, remove the stock front twin "I" beam axle pivot drop bracket from the stock location and discard the stock front twin "I" beam axle pivot drop bracket and hardware.

10. Working on the driver side, remove the stock spring from the stock location. The stock spring may be discarded. Save the stock spring eye hardware for later re-installation.

11. Locate (2) MO2070 front spring eye shackle bushings, (1) S10008 front spring eye shackle sleeve and (1) polyurethane lube pack. Working on the driver side, remove the stock front spring shackle from the stock frame mount and save the stock hardware for later re-installation. Carefully press out the stock bushing and sleeve from the stock spring shackle and discard the

stock bushing and sleeve. Install the new bushings and sleeve into the stock front spring eye shackle. **Special Note: Make sure to use the new polyurethane lube pack prior to inserting the new bushings back into the new front spring shackle. This will increase the life of the bushing, prevent squeaking and help with ride quality.** Install the stock front spring eye shackle back into the stock location using the stock hardware that was removed earlier in this step. **Make sure to use thread locker or locktite on this bolt. Do not tighten at this point.**

12. Locate (1) new front leaf springs. Working on the front and rear eyelet's of the new front leaf spring, remove the new sleeves and bushings from each end of the new front spring and set a side for later re-installation.

13. Locate (1) new polyurethane lube pack. Spread the new polyurethane over the new bushings that were removed from step # 12 and re-install them back into the new front spring assembly. Re-install the new sleeves back into the previously installed bushings. **Special Note: Make sure to use the new polyurethane lube packs prior to inserting the new bushings back into the new front springs. This will increase the life of the bushing, prevent squeaking and help with ride quality.**

14. Working on the driver side, install the new front spring back into the stock location and secure using the stock hardware that was removed from step # 10. **Special Note: The new front spring has an off-set centering bolt, the shorter end of the spring needs to be installed towards the front of the vehicle. Make sure to use thread locker or locktite on these bolts.** Torque the front spring eye hanger hardware to **120 ft lbs.** **Special Note: Do not torque the front spring eye shackle hardware at this time. Once the vehicle is lowered to the ground, the upper and lower front spring eye shackle hardware will be torque to 40 ft lbs.**

**See Illustration # 2 / Front Spring Shackle  
See Illustration # 3 / Rear Spring Hanger**

15. Locate the new front twin "I" beam axle pivot drop bracket, (5) 9/16" x 1 1/2" bolts, (10) 9/16" flat washers and (5) 9/16" unitorque nuts from hardware bag F2507NB. Secure the new front twin "I" beam axle pivot drop bracket into the (2) upper stock holes using the new 9/16" x 1 1/2" bolts and hardware. Torque to **120 ft lbs.** **Make sure to use thread locker or locktite on these bolts. Using the (3) stock holes in the stock cross member as a guide, carefully drill (3) 9/16" holes into the new front twin "I" beam axle pivot drop bracket.** Secure the new front twin "I" beam axle pivot drop bracket to the front cross member using the new 9/16" x 1 1/2" bolts and hardware. Torque to **120 ft lbs.** **Make sure to use thread locker or locktite on these bolts.**

**See Illustration # 4**

16. Carefully raise up on both hydraulic floor jacks that are supporting the front twin "I" beam axle until the stock front twin "I" beam axle seats properly with the new front spring pack.

17. Locate the upper and lower U-bolt plates that were removed from step # 6, (2) 9/16" x 3" x 10 1/2" square U-bolts, (4) 9/16" U-bolt high nuts and (4) 9/16" U-bolt washers from hardware bag 916NW. Working on the driver side, install the stock upper and lower U-bolt plates into the stock location and secure the newly installed front spring to the stock front twin "I" beam axle using the new 9/16" x 3" x 10 1/2" square U-bolts and hardware. **Torque to 110 ft lbs.**

18. Locate (1) 9/16" x 3 1/2" cam bolt, (2) cam washers and (1) 9/16" unitorque nut from hardware bag CAM1NB. Carefully raise up on the hydraulic floor jack that is supporting the front twin "I" beam axle until the front twin "I" beam axle seats properly into the new front twin "I" beam axle pivot drop bracket. Secure the stock front twin "I" beam axle to the new front twin "I" beam axle pivot drop bracket using the new 9/16" x 3 1/2" cam bolt and hardware. **Make sure to use thread locker or locktite. Torque to 115 ft lbs. Special Note: For now, adjust the new cam bolt to the center position. After the completion of the installation, take the vehicle directly to an alignment shop for a proper front end alignment.**

**See Illustration # 5**

19. Carefully remove both hydraulic floor jacks from under the stock front twin "I" beam axle.

20. Place a pair of hydraulic floor jacks under the rear twin "I" beam axle.

21. Working on the passenger side, remove the stock U-bolts from the stock location. The stock U-bolts and hardware may be discarded. Place the stock upper and lower U-bolt plates a side for later re-installation.

22. Working on the stock rear twin "I" beam axle pivot drop bracket, remove the stock bolt that connects the stock rear twin "I" beam axle to the stock rear twin "I" beam axle pivot drop bracket and discard the stock hardware.

23. Carefully lower down on the hydraulic floor jacks that are supporting the rear twin "I" beam axle approximately 5". **Special Note: Take special care not to kink or over extend any brake lines and or hoses.** This will allow enough room for the new front springs and new rear twin "I" beam axle pivot drop bracket to be installed into the stock location.

24. Next, remove the stock rear twin "I" beam axle pivot drop bracket from the stock location and discard the stock rear twin "I" beam axle pivot drop bracket and hardware.

25. Next, remove the stock rear twin "I" beam axle pivot drop bracket from the stock location and discard the stock rear twin "I" beam axle pivot drop bracket and hardware.

26. Working on the passenger side, remove the stock spring from the stock location. The stock spring may be discarded. Save the stock spring eye hardware for later re-installation.

27. Locate (2) MO2070 front spring eye shackle bushings, (1) S10008 front spring eye shackle sleeve and (1) polyurethane lube pack. Working on the passenger side, remove the stock front spring shackle from the stock frame mount and save the stock hardware for later re-installation. Carefully press out the stock bushing and sleeve from the stock spring shackle and discard the stock bushing and sleeve. Install the new bushings and sleeve into the stock front spring eye shackle. **Special Note: Make sure to use the new polyurethane lube packs prior to inserting the new bushings back into the new front spring shackle. This will increase the life of the bushing, prevent squeaking and help with ride quality.** Install the stock front spring eye shackle back into the stock location using the stock hardware that was removed earlier in this step. **Do not tighten at this point.**

**See Illustration # 2**

28. Locate (1) new front leaf spring. Working on the front and rear eyelet's of the new front leaf spring, remove the new sleeves and bushings from each end of the new front spring and set a side for later re-installation.

29. Locate (1) new polyurethane lube pack. Spread the new polyurethane over the new bushings that were removed from step # 28 and re-install them back into the new front spring assembly. Re-install the new sleeves back into the previously installed bushings. **Special Note: Make sure to use the new polyurethane lube packs prior to inserting the new bushings back into the new front springs. This will increase the life of the bushing, prevent squeaking and help with ride quality.**

30. Working on the passenger side, install the new front spring back into the stock location and secure using the stock hardware that was removed from step # 26. **Special Note: The new front spring has an off-set centering bolt, the shorter end of the spring needs to be installed towards the front of the vehicle. Make sure to use thread locker or locktite on these bolts.** Torque the front spring eye hanger hardware to **120 ft lbs.** **Special Note: Do not torque the front spring eye shackle hardware at this time. Once the vehicle is lowered to the ground, the upper and lower front spring eye shackle hardware will be torque to 40 ft lbs.**

**See Illustration # 2 / Front Spring Shackle  
See Illustration # 3 / Rear Spring Hanger**

31. Locate the new rear twin "I" beam axle pivot drop bracket, (5) 9/16" x 1 1/2" bolts, (10) 9/16" flat washers and (5) 9/16" unitorque nuts from hardware bag F2507NB. Secure the new rear twin "I" beam axle pivot drop bracket into the (2) upper stock holes using the new 9/16" x 1 1/2" bolts and hardware. Torque to **120 ft lbs.** **Make sure to use thread locker or locktite on these bolts. Using the (3) stock holes in the stock cross member as a guide, carefully drill (3) 9/16" holes into the new rear twin "I" beam axle pivot drop bracket.** Secure the new rear twin "I" beam axle pivot drop bracket to the front cross member using the new 9/16" x 1 1/2" bolts and hardware. Torque to **120 ft lbs.** **Make sure to use thread locker or locktite on these bolts.**

**See Illustration # 6**

32. Carefully raise up on the both hydraulic floor jacks that are supporting the rear twin "I" beam axle until the stock rear twin "I" beam axle seats properly with the new front spring pack.

33. Locate the upper and lower U-bolt plates that were removed from step # 21, (2) 9/16" x 3" x 10 1/2" square U-bolts, (4) 9/16" U-bolt high nuts and (4) 9/16" U-bolt washers from hardware bag 916NW. Working on the passenger side, install the stock upper and lower U-bolt plates into the stock location and secure the newly installed front spring to the stock rear twin "I" beam using the new 9/16" x 3" x 10 1/2" square U-bolts and hardware. **Torque to 110 ft lbs.**

34. Locate (1) 9/16" x 3 1/2" cam bolt, (2) cam washers and (1) 9/16" unitorque nut from hardware bag CAM1NB. Carefully raise up on the hydraulic floor jack that is supporting the rear twin "I" beam axle until the rear twin "I" beam axle seats properly into the new rear twin "I" beam axle pivot drop bracket. Secure the stock rear twin "I" beam axle to the new rear twin "I" beam axle pivot drop bracket using the new 9/16" x 3 1/2" cam bolt and hardware. **Make sure to use thread locker or locktite. Torque to 115 ft lbs. Special Note: For now, adjust the new cam bolt to the center position. After the completion of the installation, take the vehicle directly to an alignment center for a proper front end alignment.**

**See Illustration # 7**

35. Carefully remove both hydraulic floor jacks from under the stock rear twin "I" beam axle.

**Special Note: If the vehicle that you are working on is not equipped with a front sway bar, please skip to step # 38**

36. Locate (1) new front sway bar drop bracket and (2) stock bolts and hardware that was removed from step # 4. Working on the driver side, install the new sway bar drop bracket to the stock frame mount. Secure using the stock hardware. **Special Note: Do not tighten at this point. Make sure to use thread locker or locktite on these bolts.** Repeat procedure on the passenger side.

**See Illustration # 8**

37. Locate (4) 7/16" x 1 1/2" bolts, (4) 7/16" unitorque nuts and (8) 7/16" flat washers from hardware bag F450NB. Working on the driver side, secure the stock front sway bar to the previously installed sway bar drop bracket using the new 7/16" x 1 1/2" bolts and hardware. **Special Note: Do not tighten at this point. Make sure to use thread locker or locktite on these bolts.** Repeat procedure on the passenger side. **Also, if you are not able to install the stock sway front bar to the new front sway bar drop brackets, you may need to perform this step once the weight of the vehicle is on the ground.** Once the stock front sway bar is attached to the new front sway bar drop brackets torque the stock and new 7/16" hardware to **45 ft lbs.**

**See Illustration # 8**

38. Locate the new pitman, the stock pitman arm hardware, the stock castle nut and the stock cotter pin that was removed from step # 3. Install the new pitman arm to the stock sector shaft located on the stock steering box, secure using the stock hardware. **Make sure to use thread locker or lock tite.** Torque to **140 ft lbs.** Next, install the stock drag link to the newly installed pitman arm and secure using the stock hardware. Make sure to install the stock cotter pin.

39. Locate the new front shocks and the stock hardware that was removed in step # 2. Working on the driver side, install the new longer shock into the stock upper and lower location and secure using the stock hardware. Repeat procedure on the passenger side. **Torque the upper and lower hardware to proper torque specifications. Refer to the torque setting sheet at the end of the installation manual.**

40. Check and double check to make sure that all steps were performed properly. Check and double check to make sure that all stock and new hardware is torque to proper torque specifications. **Special Note: Refer to the owners manual and the torque setting sheet at the end of the installation manual.**

41. Install the tires and wheels and carefully lower the vehicle to the ground.

42. If you were not able to install the stock sway bar to the new front sway bar drop brackets in step # 37, perform this step once the weight of the vehicle is on the ground.

43. Working on the driver side, inspect the stock front brake lines to make sure that they are not over extended. If the stock brake lines are over extended, carefully bend the stock brake line bracket down for proper brake line clearance. Repeat procedure on the passenger side.

**Congratulations, Front End Installation Complete**

#### **Rear End Installation:**

44. To begin installation, block the front tires of the vehicle so that the vehicle is stable and can't roll forward. Safely lift the rear of the vehicle and support the frame with jack stands. Place a jack stand on both the driver and passenger side. Next, remove the stock wheels and tires from both sides.

45. Place two hydraulic floor jacks under the rear axle. One on the driver side and one on the passenger side. Raise up on both hydraulic floor jacks at the same time until they come in contact with the rear axle.

46. Working on the driver side, remove the stock shock from the stock upper and lower mounting points and save the stock hardware for later re-installation. The stock shocks may be discarded. **Special Note: New longer rear shocks are needed after the completion of the installation. If you have not already ordered your new rear shocks, please contact Tuff Country or your local Tuff Country dealer and order part # 61301.** Repeat procedure on passenger side.

47. Working on the driver side, remove the stock U-bolts from the stock location. The stock U-bolts and hardware may be discarded. Set the stock upper U-bolt plate a side for later re-installation. Repeat procedure on the passenger side.

48. Carefully lower down on both hydraulic floor jacks at the same time allowing enough room for the new blocks and add-a-leafs to be installed. **Special Note: Make sure not to over extended any brake lines or hoses when lowering axle.**

49. Locate (2) new rear add-a-leafs, (2) new 3/8" centering bolts and nuts from hardware bag CB38. Working on the driver side, place a pair of "C" clamps around the rear springs about 2" from the stock spring clamps. Safely remove the stock rear centering bolt and discard. Install the new rear add-a-leaf into the stock spring assembly. Secure the new rear add-a-leaf to the stock spring assembly using the new 3/8" center bolt and nut. **Special Note: The new rear add-a-leaf should be installed into the stock spring assembly in progression in order. The new rear add-a-leaf has an off set centering bolt hole, the longer end of the new add-a-leaf needs to be installed towards the rear of the vehicle. Also Tuff Country EZ-Ride Suspension recommends not using any air tools when installing the new rear add-a-leafs into the stock spring assembly. If air tools are used the centering bolt may strip, causing the stock spring assembly to come apart.** Torque the new centering bolt to **40 ft. lbs.** With a suitable cutting tool, cut off the excess thread from the new centering bolt. Repeat procedure on passenger side.

**See Illustration # 9**

50. Locate (2) new rear lifted blocks. Working on the driver side, install the new rear lifted block between the stock axle and the stock spring assembly. **Special Note: The new rear lifted block has a slight taper to it, make sure to install the new rear lifted block with the smaller end towards the front of the vehicle.** Repeat procedure on the passenger side. Carefully raise up on both hydraulic floor jacks at the same time until the newly installed lifted blocks seat properly with the stock spring assembly. **Special Note: Make sure that the nipple on the new rear lifted block seats properly into the stock spring perch.**

**See Illustration # 10**

51. Locate (4) new 5/8" x 3 5/8" x 14 5/8" Round U-bolts, the stock upper U-bolt plates that were removed from step # 47, (8) new 5/8" U-bolt high nuts and (8) new 5/8" U-bolt washers from hardware bag 58NW. Working on the driver side, install the stock upper U-bolt plate into the stock location. Install the new U-bolts into the stock location and secure using the new 5/8" x 3 5/8" x 14 5/8" round U-bolts and hardware. Torque to **130 ft lbs.** Repeat procedure on the passenger side.

**See Illustration # 10**

52. Locate the new rear shocks and the stock shock hardware that was removed from step # 46. Working on the driver side, install the new shock into the stock upper and lower location and secure using the stock hardware. Torque to **75 ft lbs.** Repeat procedure on the passenger side.

53. Carefully remove both hydraulic floor jacks from under the rear axle.

54. Check and double check to make sure that all steps were performed properly. Check and double check to make sure that all stock and new hardware is torque to proper torque specifications. **Special Note: Refer to the owners manual and the torque setting sheet at the end of the installation manual.**

55. Install the tires and wheels and carefully lower the vehicle to the ground.

## **Congratulations, Installation Complete**

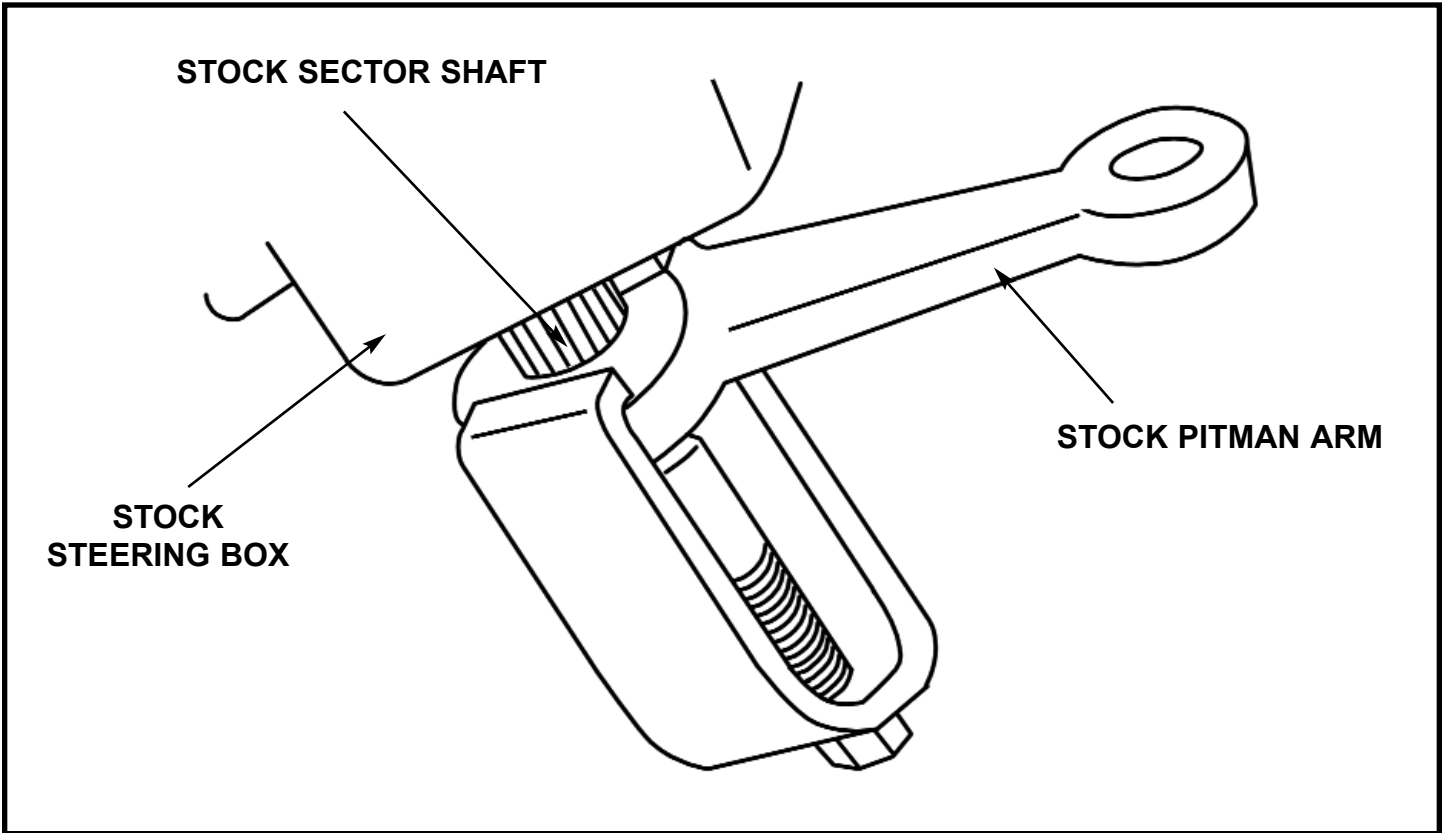
**Once the installation is complete, take the vehicle directly to an alignment shop for proper front end alignment.**

**Special Post Installation Procedure: Make sure that the new mounting hardware that connects the new twin "I" beam axle pivot drop brackets to the stock location are checked every 3000 miles for proper torque, if these bolts are not properly torqued, they will loosen up and could cause serious damage to the new twin "I" beam axle pivot drop brackets and or vehicle. Tuff Country EZ-Ride Suspensions take no responsibility for improper installation or improper post installation procedure.**

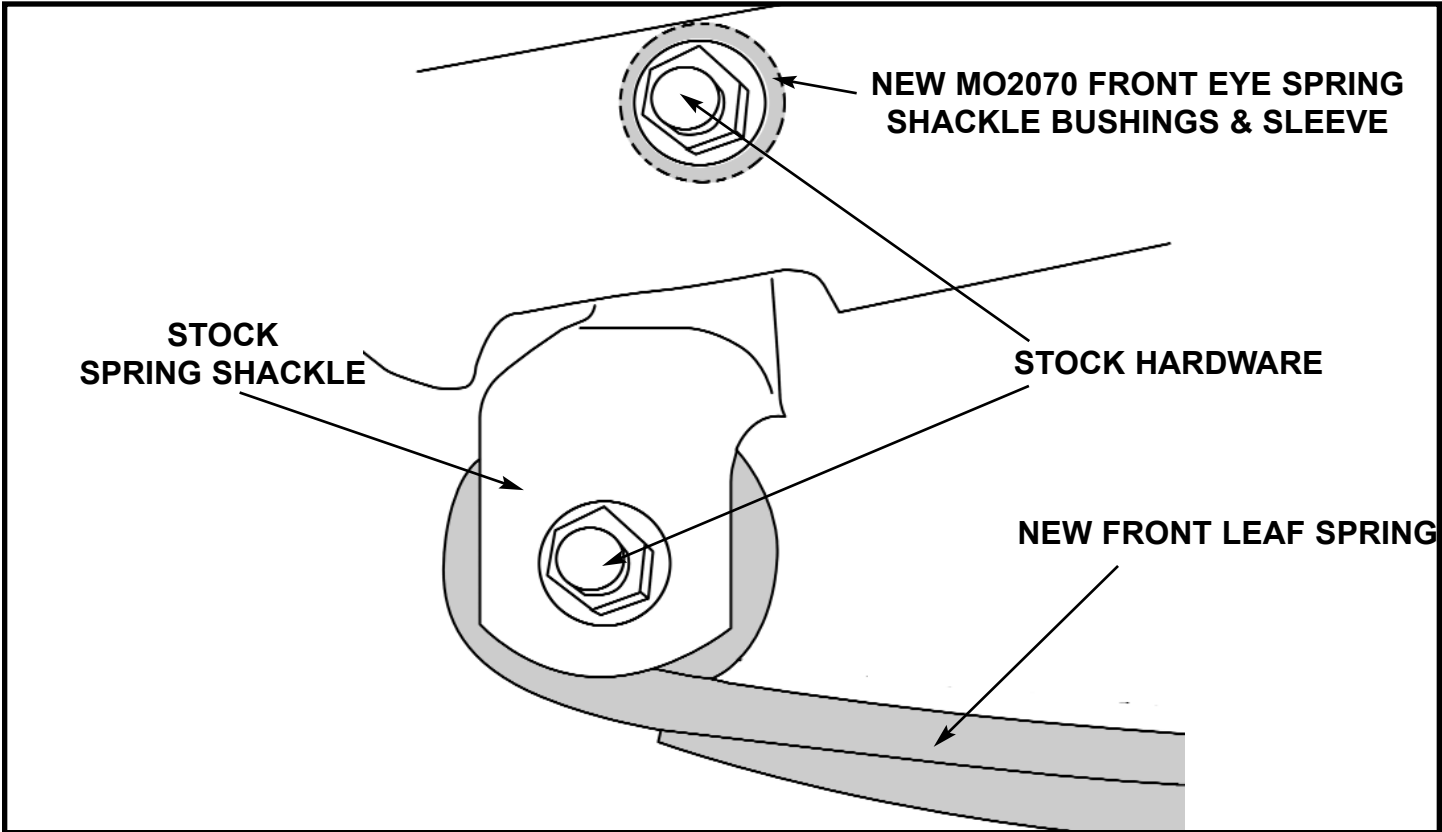
**If you have any questions and or concerns, please feel free to contact Tuff Country EZ-Ride Suspension. (801) 280-2777**

### **Torque Settings**

<b>5/16"</b>	<b>15—18 ft lbs.</b>
<b>3/8"</b>	<b>28—32 ft lbs.</b>
<b>7/16"</b>	<b>30—35 ft lbs.</b>
<b>1/2"</b>	<b>65—85 ft lbs.</b>
<b>9/16"</b>	<b>85—120 ft lbs.</b>
<b>5/8"</b>	<b>95—130 ft lbs.</b>
<b>3/4"</b>	<b>100—140 ft lbs.</b>

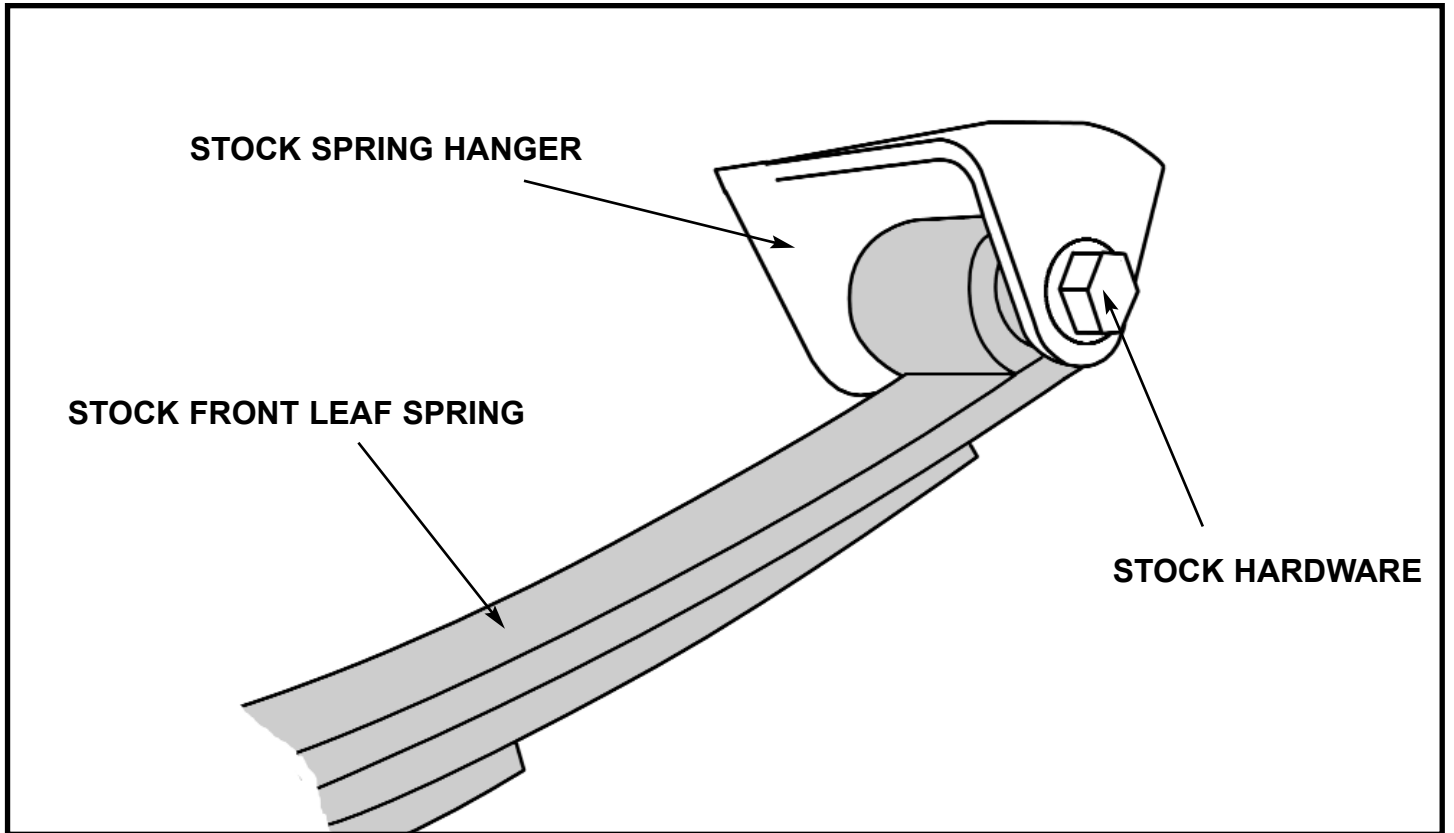


**ILLUSTRATION # 1**

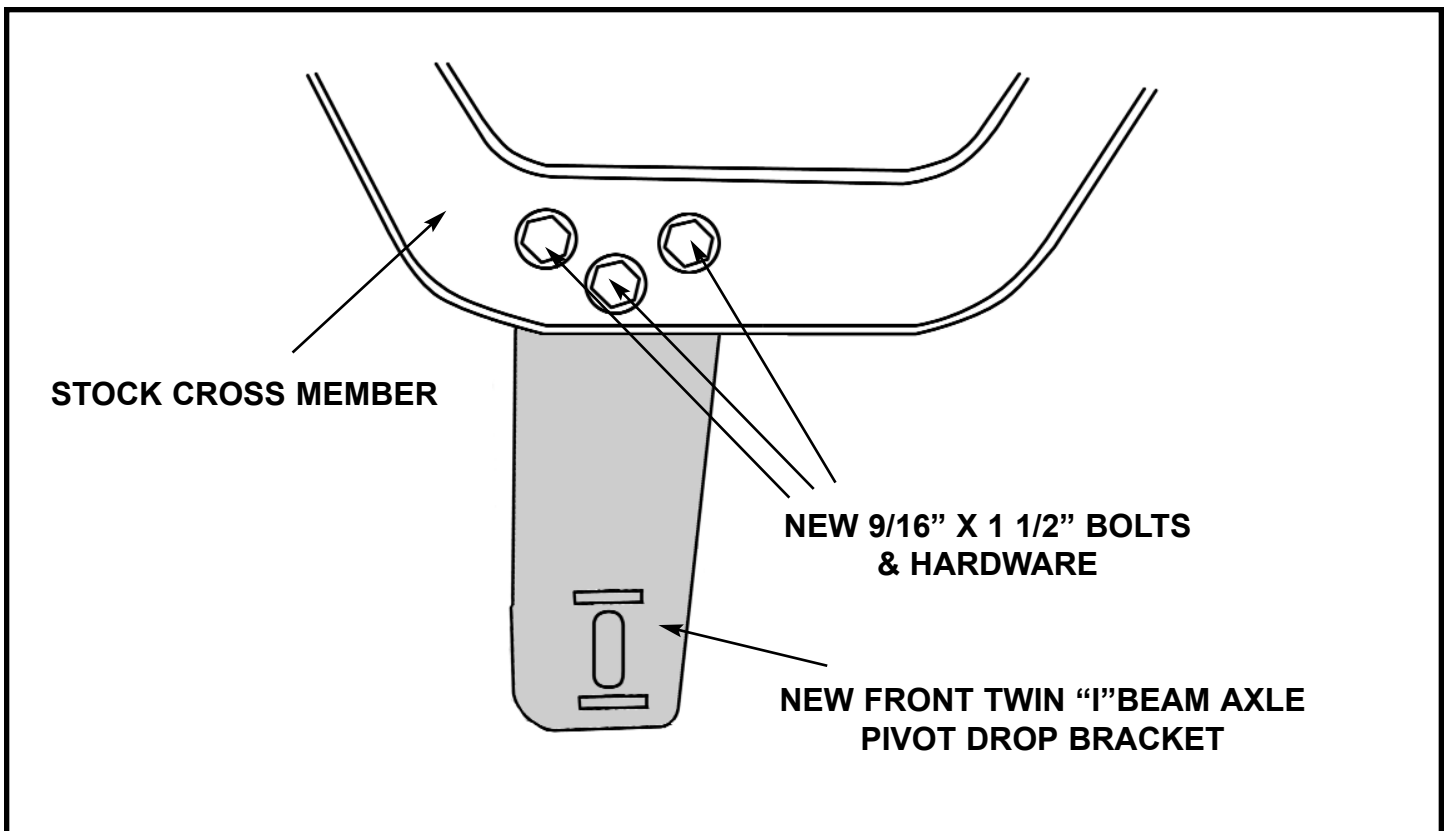


**ILLUSTRATION # 2**

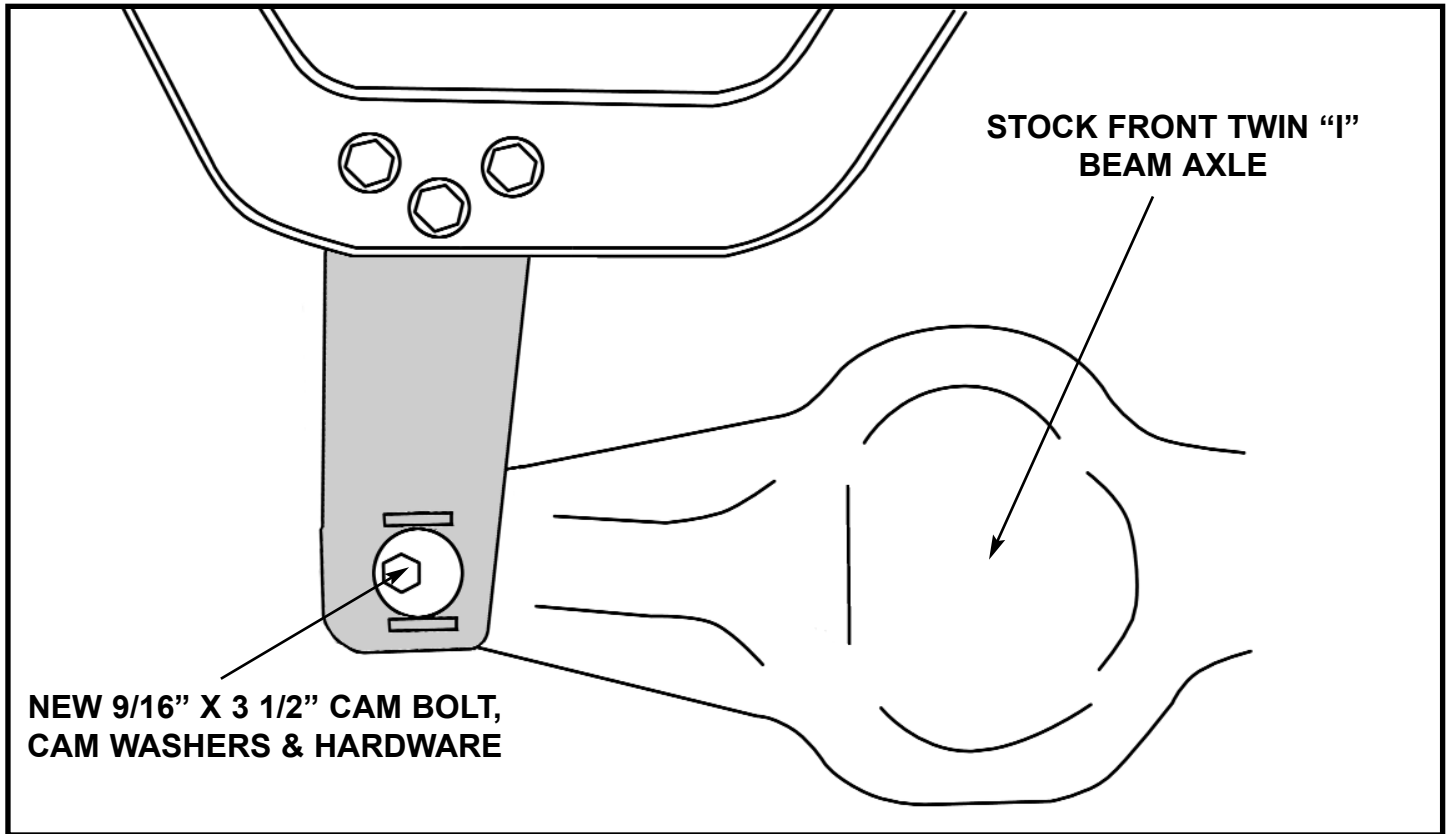




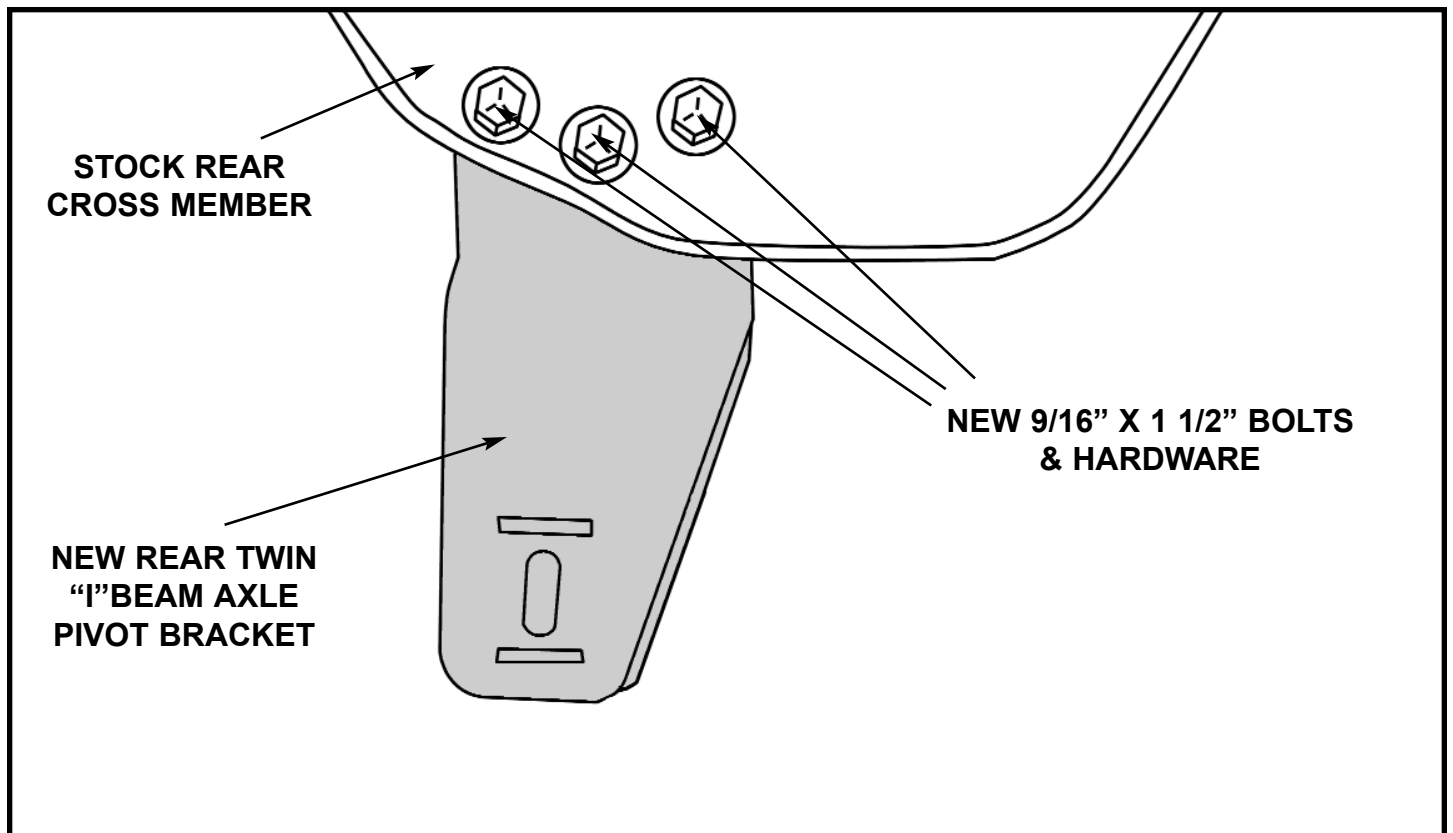
**ILLUSTRATION # 3**



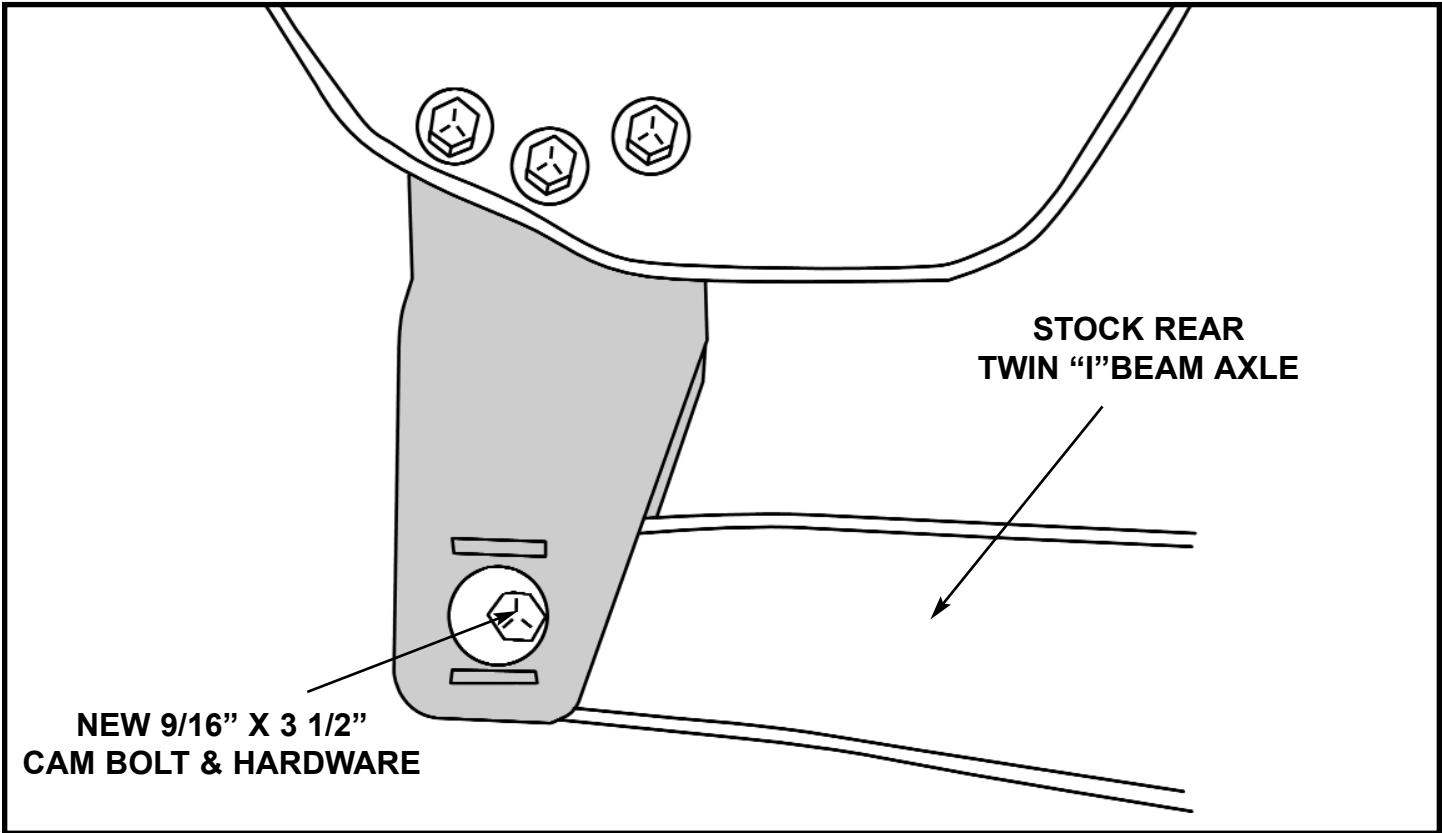
**ILLUSTRATION # 4**



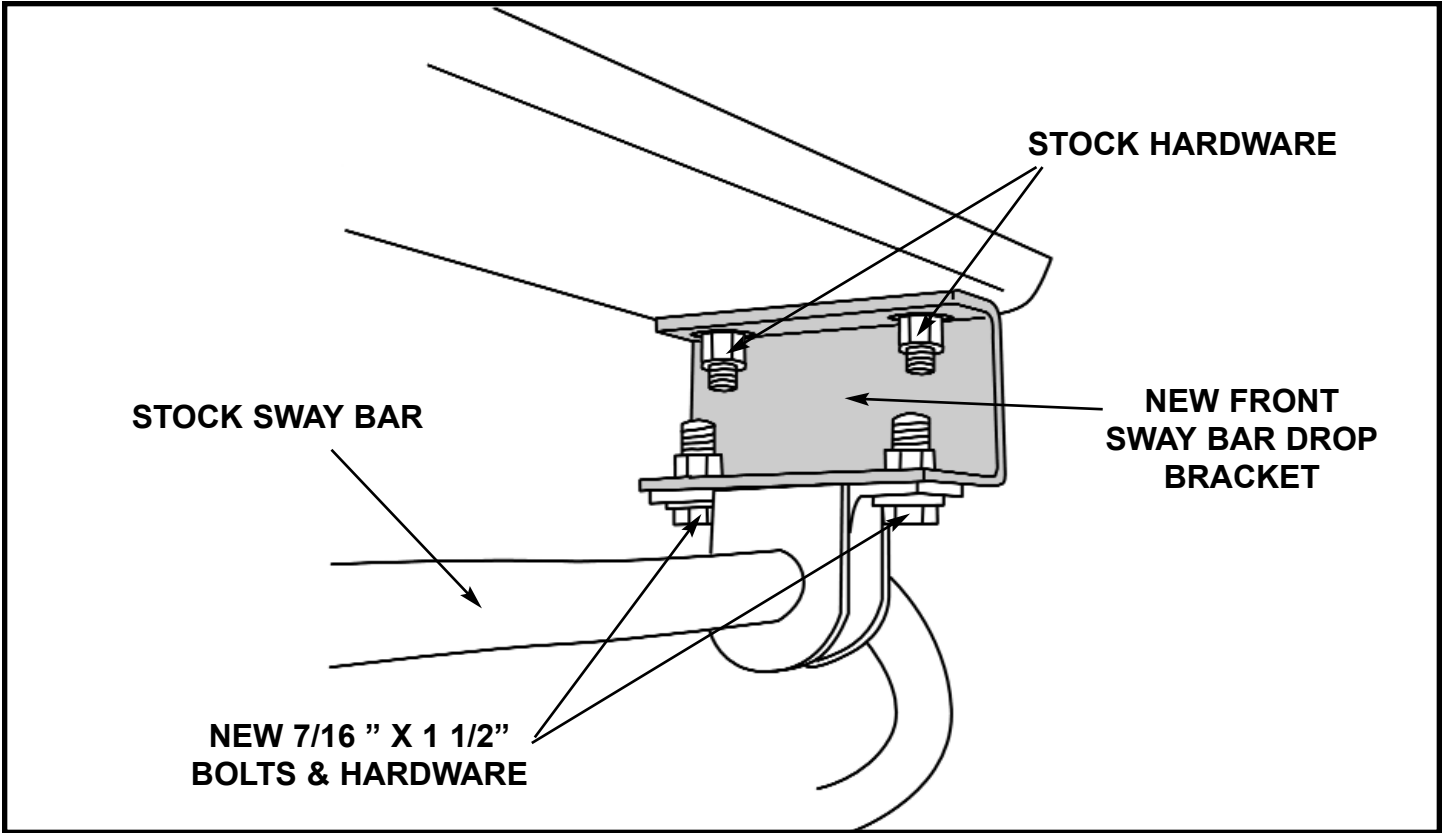
**ILLUSTRATION # 5**



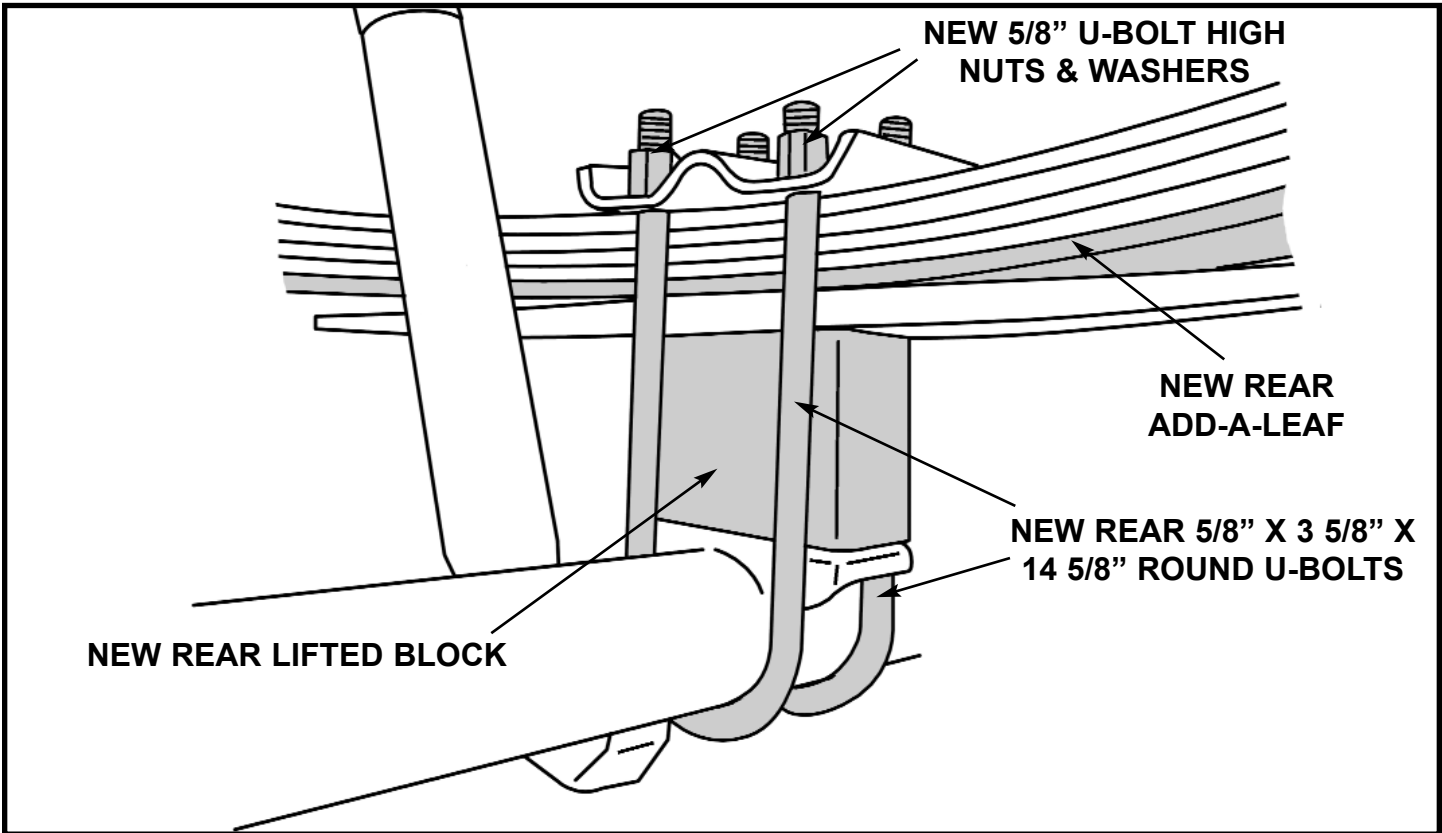
**ILLUSTRATION # 6**



**ILLUSTRATION # 7**



**ILLUSTRATION # 8**



**ILLUSTRATION # 9**

